

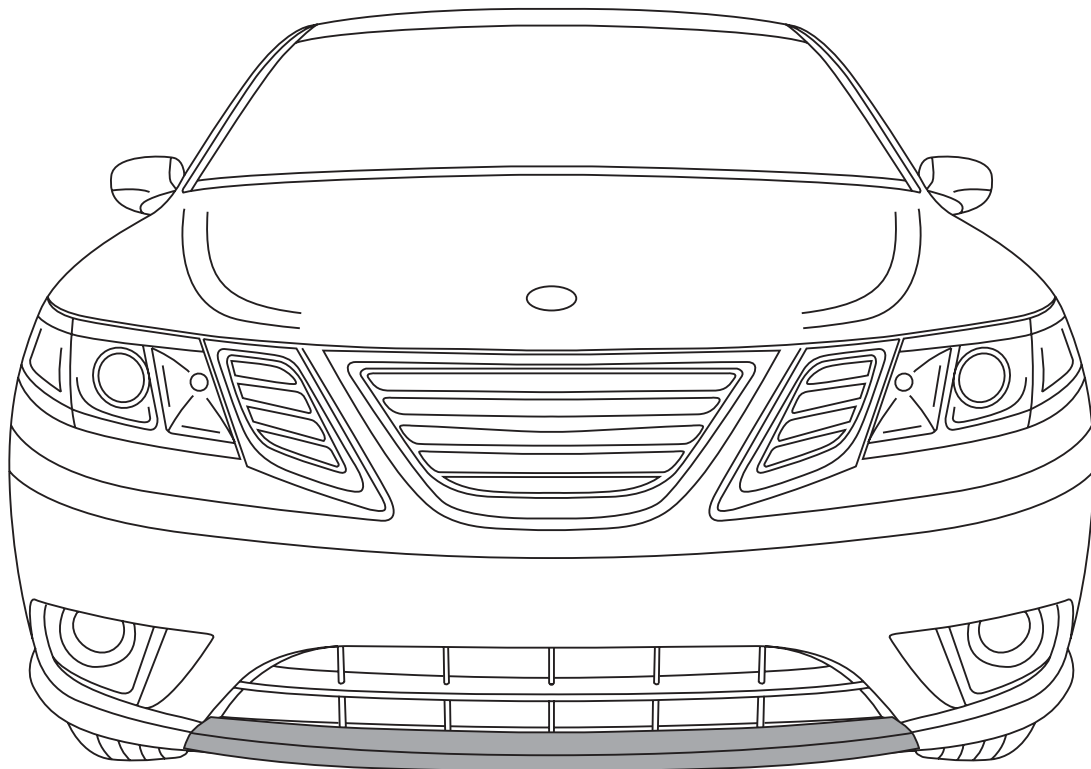

**MONTERINGSANVISNING • INSTALLATION INSTRUCTIONS
MONTAGEANLEITUNG • INSTRUCTIONS DE MONTAGE**

Accessories Part No.	Date	Instruction Part No.	Replaces
32 025 844	May 2007	32 026 186	

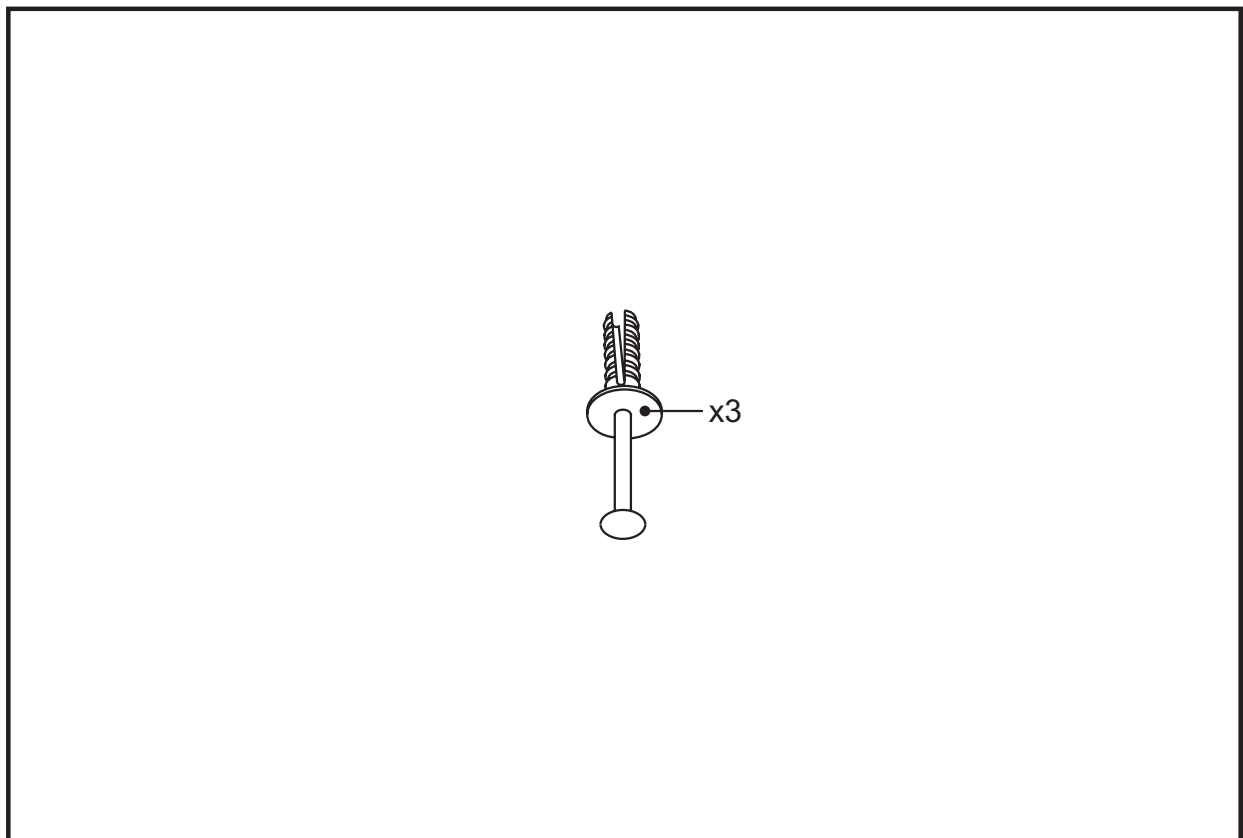

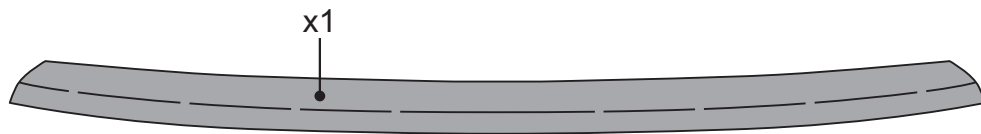

重要事項



使用附件之前請仔細閱讀安裝說明。

安裝說明書應置於車內。

如有不確定事項，請聯絡距離最近的經銷商。

請勿在零件安裝後5小時內駕駛車輛！



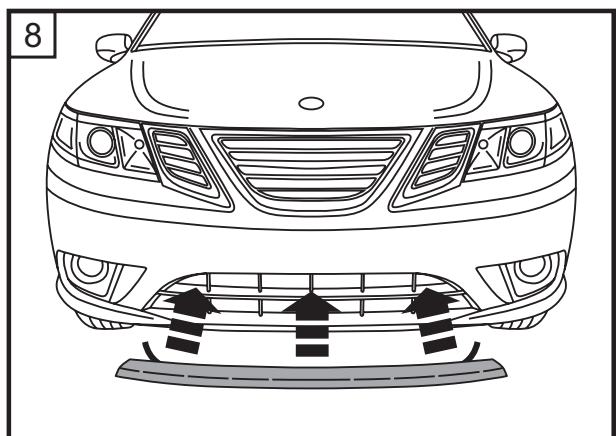
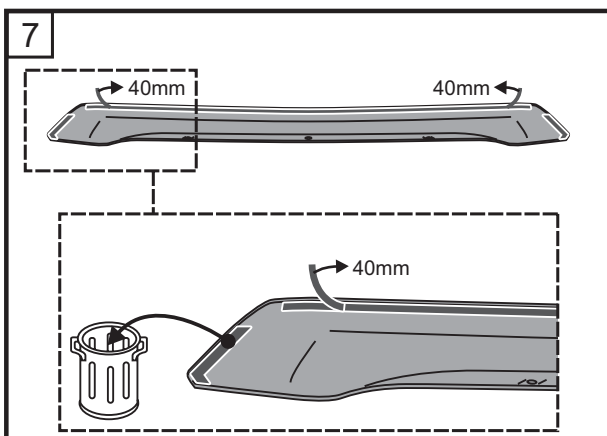
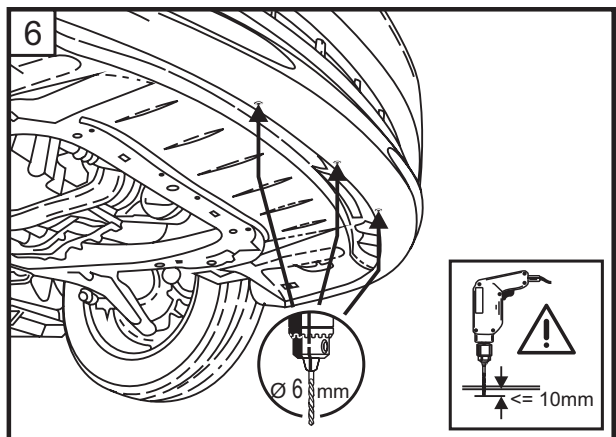
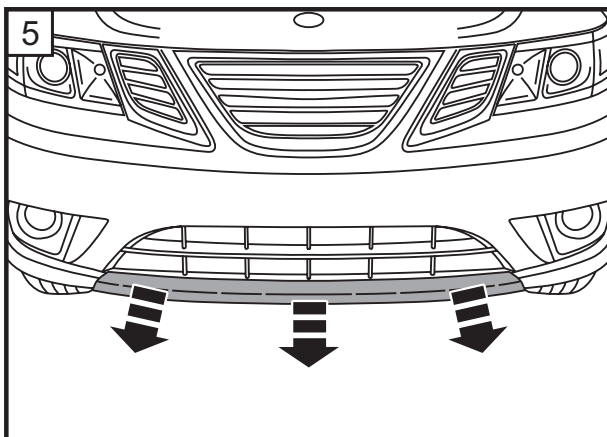
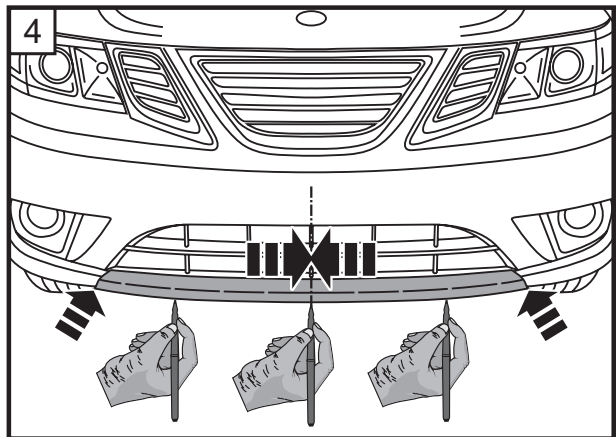
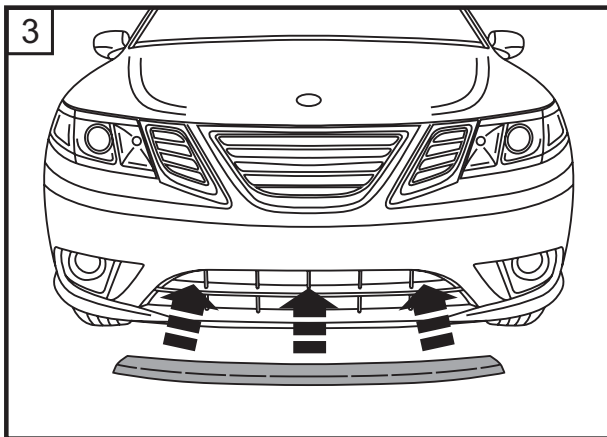
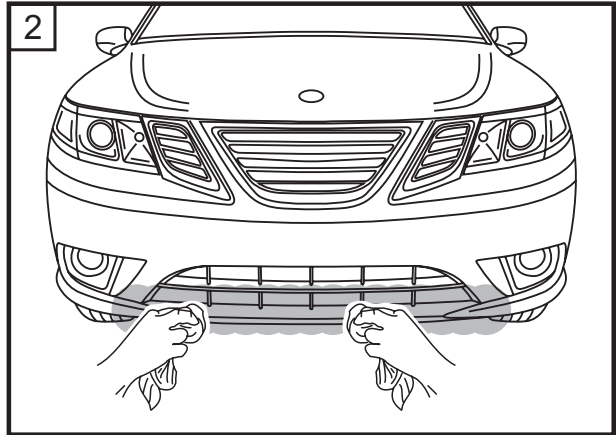
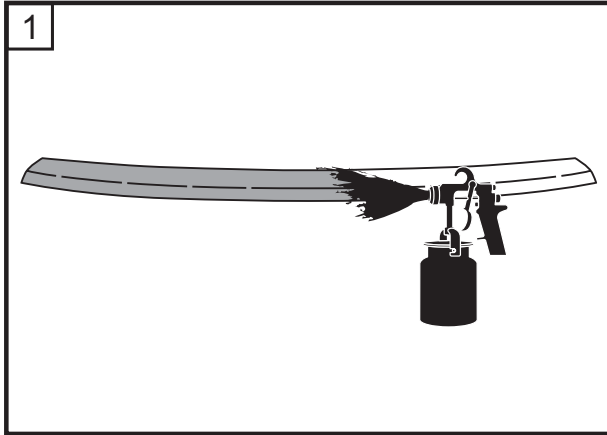

請勿在零件安裝後24小時內高速行駛車輛（車速大於100km/h）！

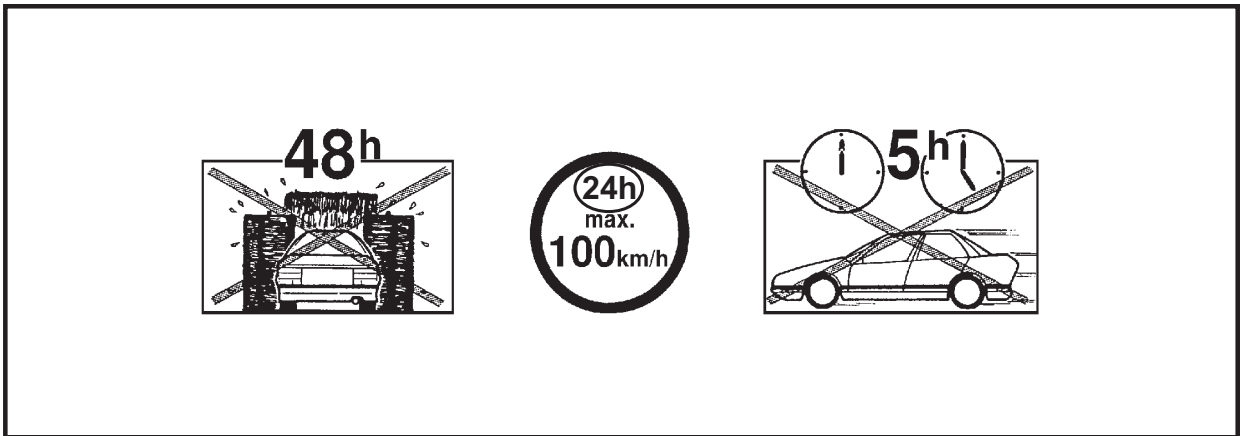
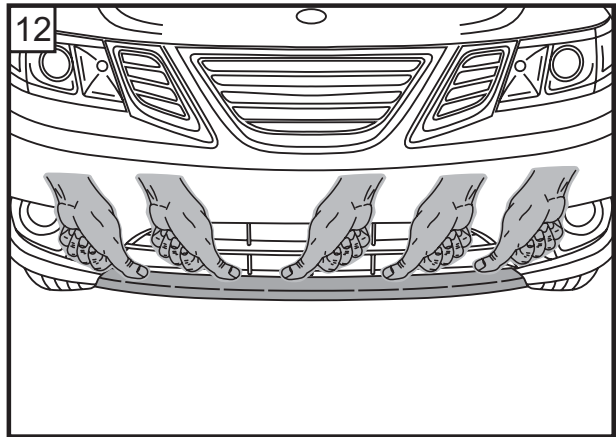
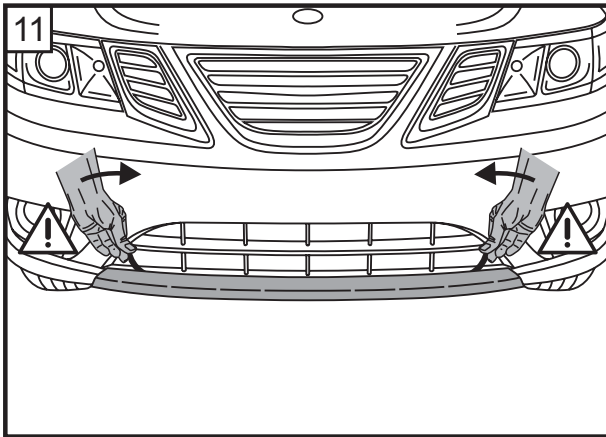
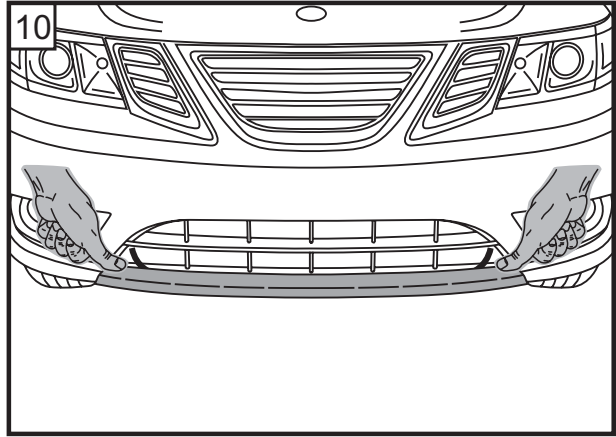
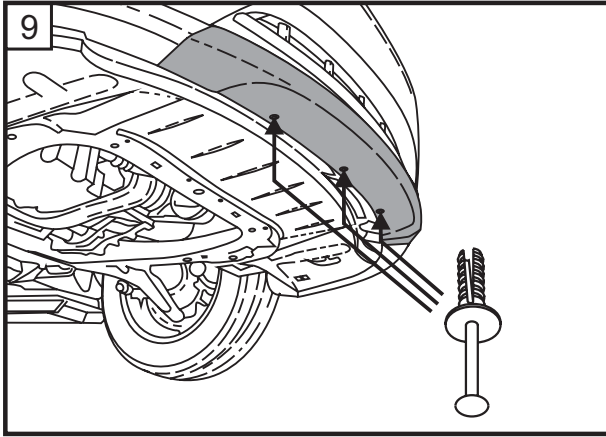
請勿在零件安裝後48小時內進行機器洗車！





已塗有底漆部分的塗裝說明

ZH		平滑地打磨已塗底漆部件 (P800-P1000)。 避免打磨底漆。
		檢查瑕疵點，修整瑕疵，再平滑地打磨修整部位 (P800-P1000)。 用適當的塑膠底漆再次噴塗打磨過的瑕疵點。
		用矽酮清洗劑進行徹底清潔。
		塗裝過程中確保部件得到充分支撐十分重要 (存在變形的危險) ! 油漆生產廠家指定的油漆塗裝與使用技巧以及廠家指定的彈性添加劑尤其重要。 材料標識應清晰地印在部件內部 (>.....<, z.B. >PUR-MF15<)。
		請勿烘烤油漆 (最高溫度40°C) !