



**MONTERINGSANVISNING · INSTALLATION INSTRUCTIONS  
MONTAGEANLEITUNG · INSTRUCTIONS DE MONTAGE**

**Saab 9-3 Z18XE M04-**

Engine block heater

Accessories Part No.	Group	Date	Instruction Part No.	Replaces
12 804 696	9:87-44	Mar 04	12 804 935	12 804 935 Aug 03

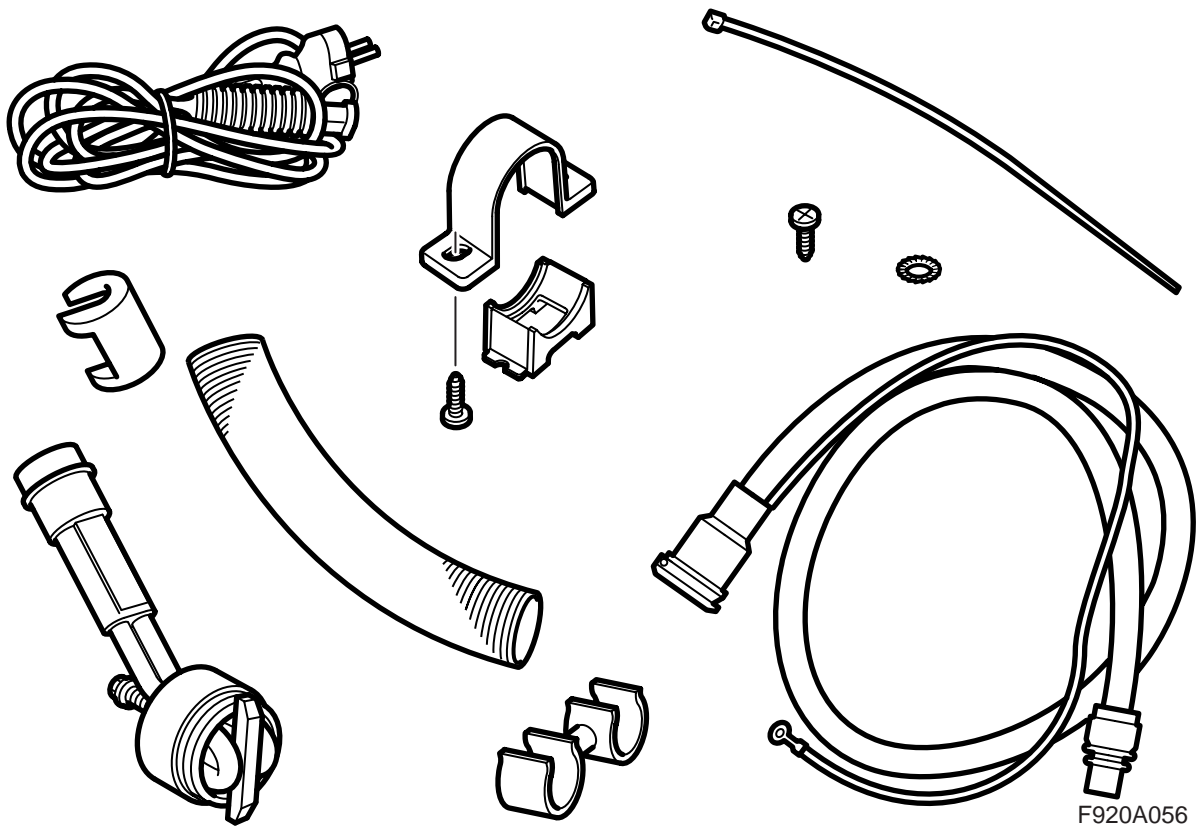

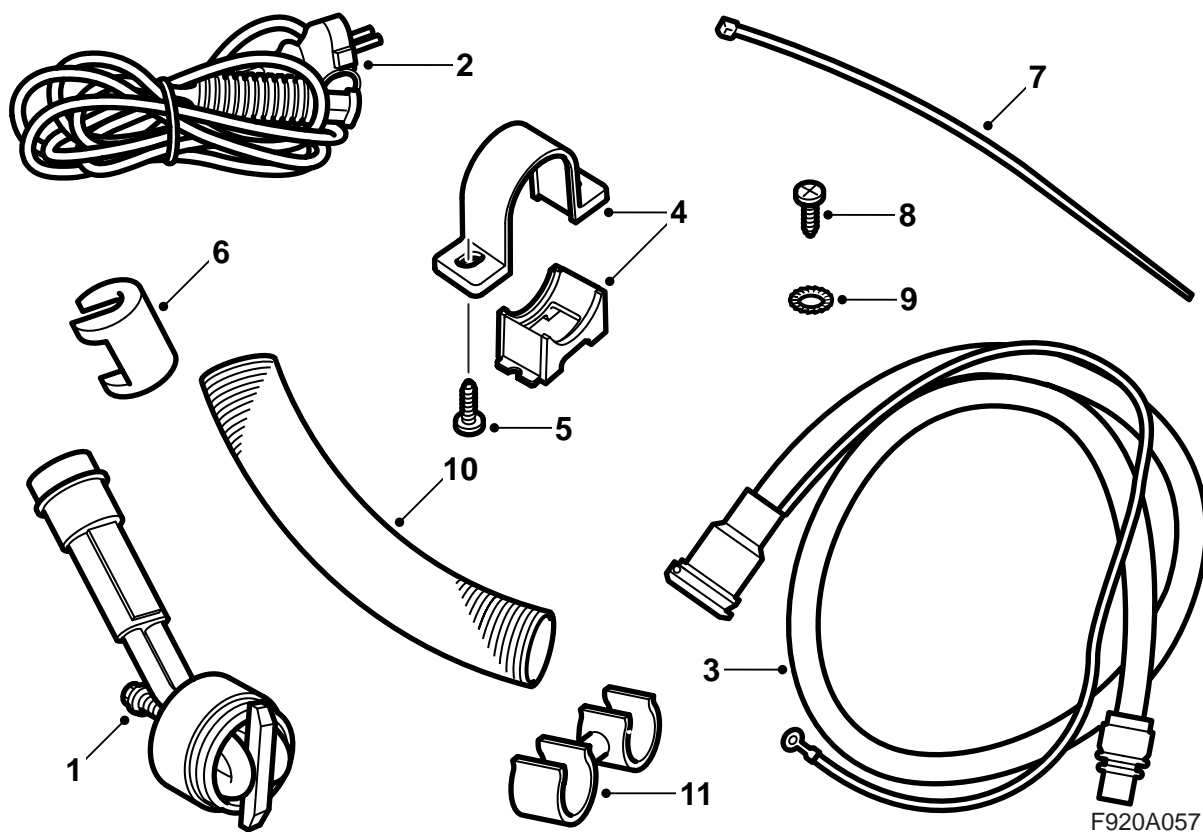

- 1 Heating element
- 2 Extension cable
- 3 Connector plug and connector cable
- 4 Holder
- 5 Screw (x2)
- 6 Locking clip
- 7 Cable tie (x5)
- 8 Screw
- 9 Star washer
- 10 Heat shield
- 11 Clamp (not used)

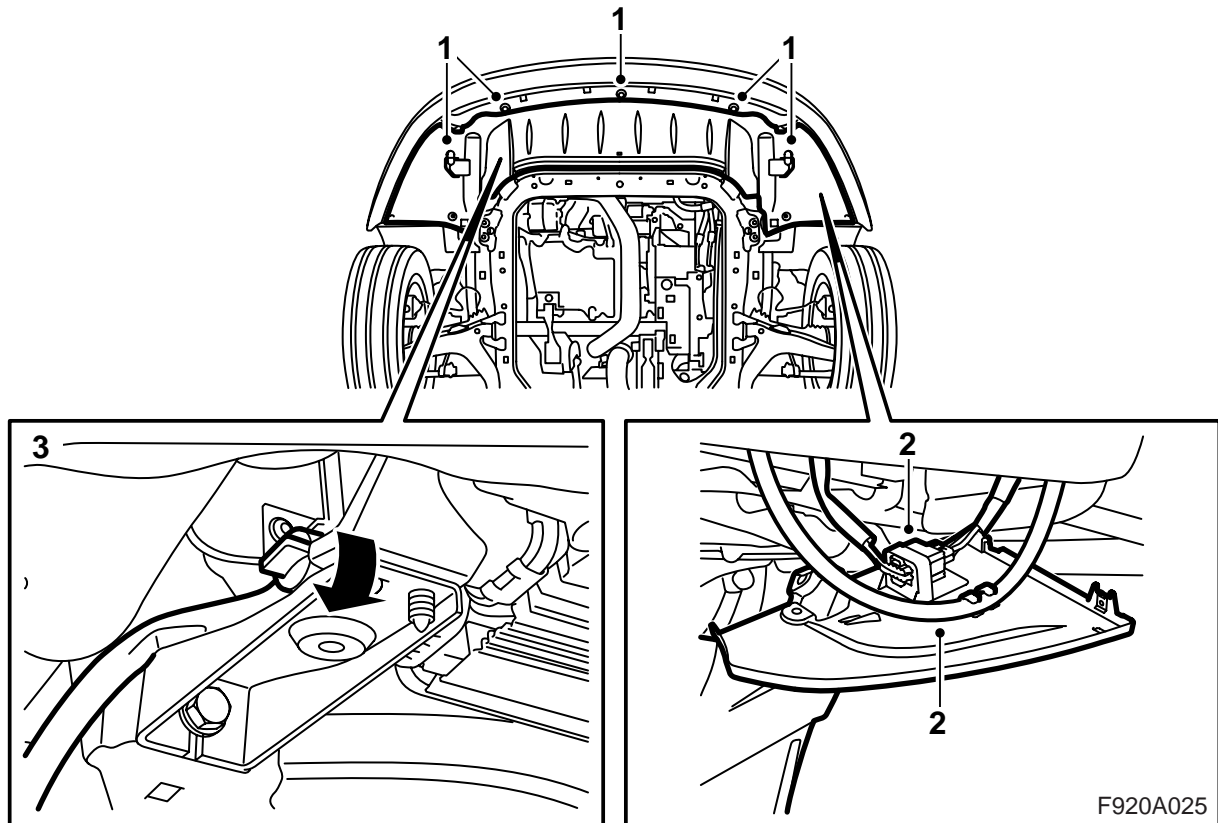

- 1 Raise the car and remove the spoiler shield.
- 2 Unplug the bumper connector and remove it from the holder on the spoiler shield.  
**Cars with headlamp washers:** Unhook the hose from the spoiler shield.
- 3 Place a receptacle under the engine, fit a hose to the radiator drain nipple, open the radiator drain plug and drain the coolant.
- 4 Lower the car.

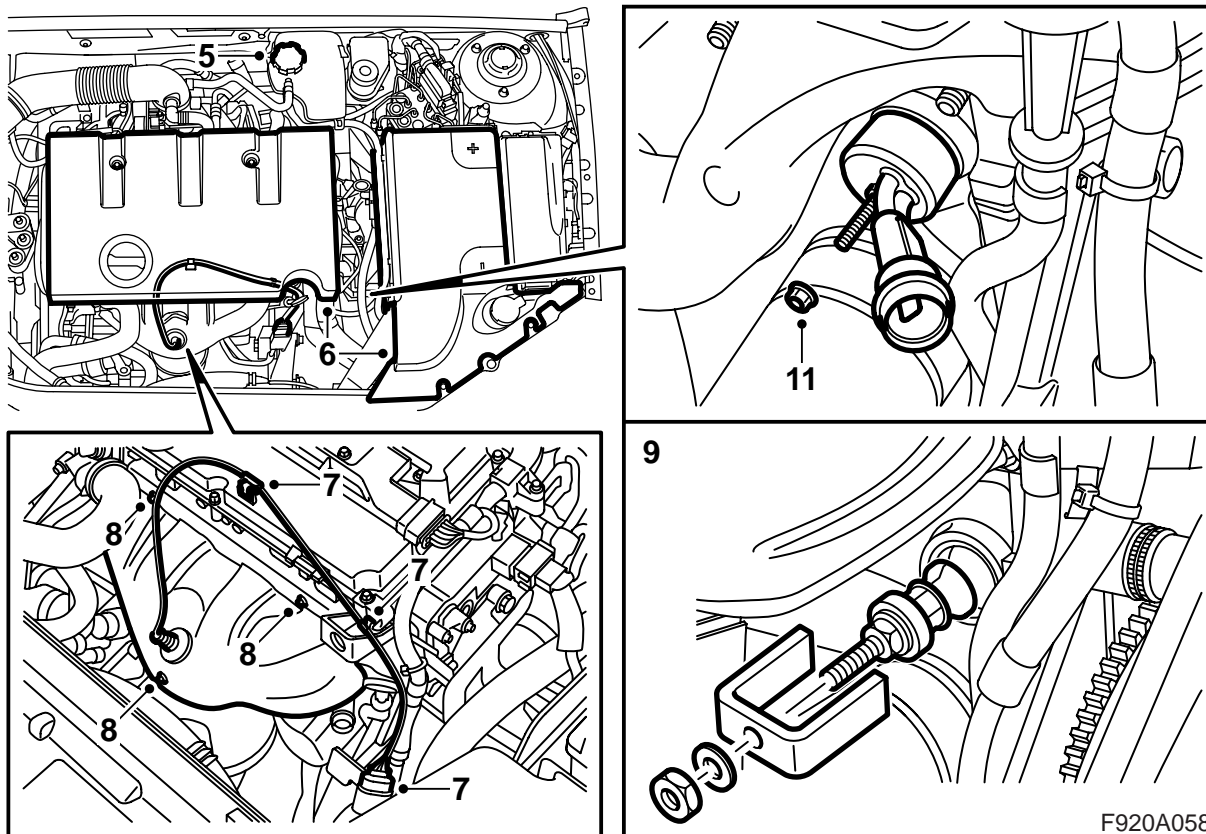

- 5 Remove the expansion tank cap.
- 6 Remove the engine cover and battery cover.
- 7 Unplug the oxygen sensor's connector and unhook the oxygen sensor's wiring harness from the clips.
- 8 Remove the exhaust manifold's heat shield.

- 12 Raise the car.
- 13 Close the radiator drain plug and remove the hose.

**⚠ WARNING**

Exercise caution if the engine is hot. Coolant is hot and there is also the risk of burns from the exhaust manifold.

- 9 Remove the frost plug using tool 260 147 020. Use a long 17 mm socket for example. Clean the sealing surface on the engine block.
- 10 Apply non-acidic Vaseline, part no. 30 06 665, or equivalent to the engine block heater O-ring.
- 11 Adjust the T-shaped support on the engine block heater, so that it is located between both heating coils, fit the heater in the cylinder block with the electrical connection located between the exhaust manifold and the oil dipstick.

**Important**

There must be approx. 10 mm between the engine block heater and the oil dipstick.

**Tightening torque 3,5 Nm (2.5 lbf ft)**

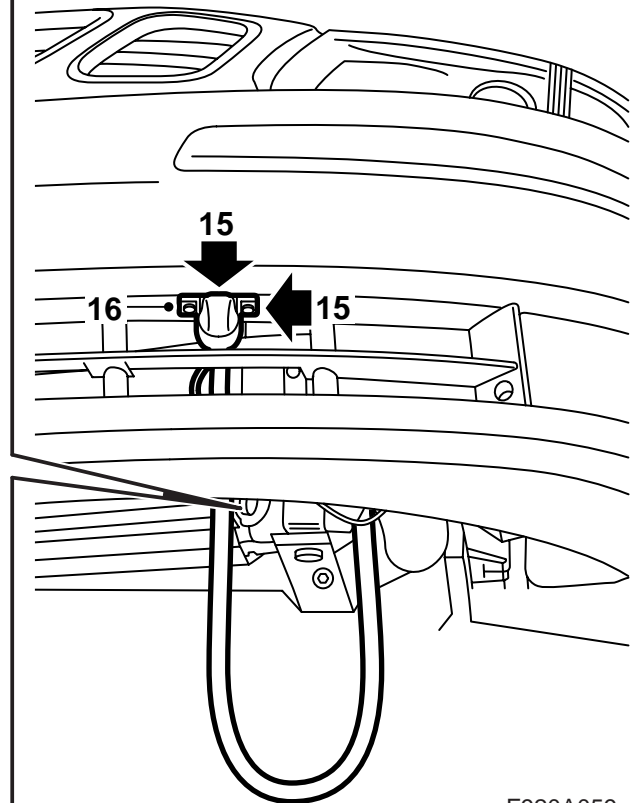
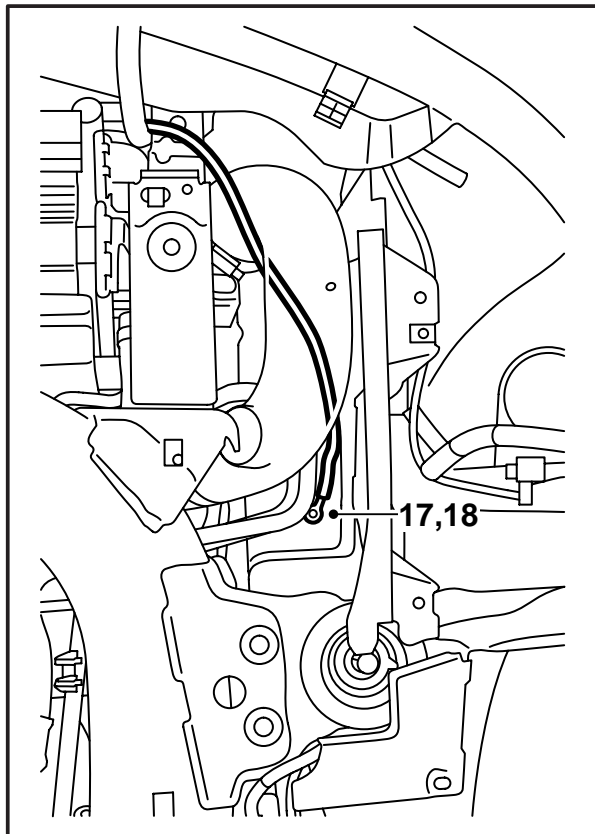

F920A059

- 14 Lower the car to a suitable working height and run the connecting cable through the bottom grille, between the pipes and between the radiator assembly and its left-hand bracket.
- 15 Mark out where the connecting plug holder is to be located, the arrow on the holder must be pointing forward, by placing the holder underneath the bumper with its front edge in line with the line in the bumper shell and in the centre of the opening. Make a hole with an awl.
- 16 Place the connector plug in the holder. The cover should open upward. Mount the holder on the bumper.
- 17 **M03-04:** Using a 3.5 mm bit, drill a hole in the structural member for the ground cable.  
**M05-:** Detach the connector located on the structural member. Using a 3.5 mm bit, drill a hole in the structural member for the ground cable.
- 19 Run the connecting cable between the radiator and the charge air hose and then straight up the side of the structural member.  
**M05-:** Attach the connector located on the structural member.
- 20 Lower the car.

### Important

Drill the hole immediately next to the square hole.

- 18 Scrape away the paint to make a good ground connection and secure the ground cable using the screw and lock washer (the lock washer should be placed between the ground cable terminal and the body). Apply thin anti-corrosion protection, part no. 30 15 971.

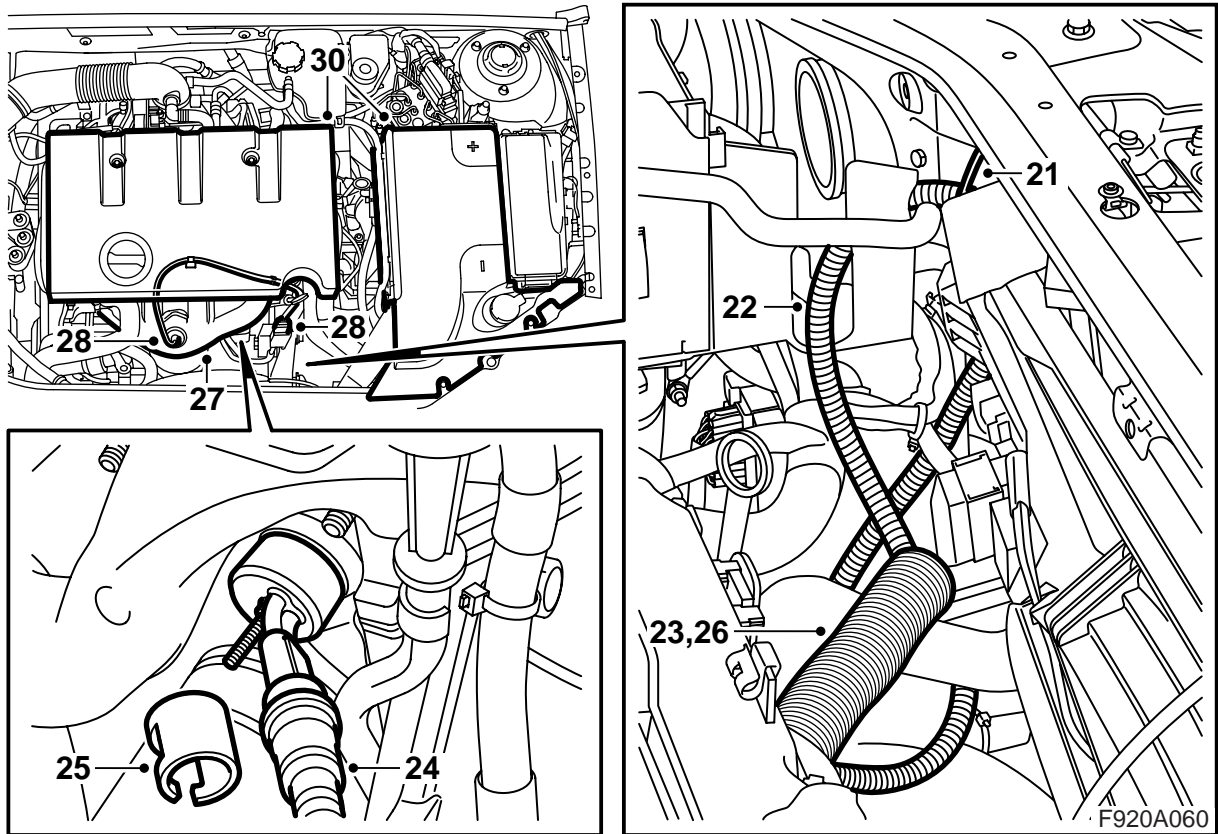

- 21 Guide the input cable up to the left of the radiator, secure the cable to the radiator's upper left-hand bracket using a cable tie.
- 22 Guide the input cable through the opening in the battery shelf and on towards the heater.
- 23 Guide the heat shield onto the cable.
- 24 Apply non-acidic Vaseline, part no. 30 15 286, or equivalent on the connecting cable O-ring and connect the cable to the engine block heater.
- 25 Fit the lock clip over the connection. A click should be heard when the lock clip is fitted correctly.
- 26 Secure the heat protection on top of the electrical connection and pinch the ends of the heat protection.
- 27 Fit the exhaust manifold's heat shield.
- 28 Fit the oxygen sensor's wiring harness into the clips and connect the connector. Fit the connector to the bracket.
- 29 Secure the connecting cable with cable ties. Bend the cable in an even curve so that it can take up any engine movement.
- 30 Fill with coolant, fit the cover on the expansion tank and check system integrity. Fit the engine cover and battery cover.

**⚠ WARNING**

It is essential to lubricate the connecting cable O-ring before it is connected and that all connections are pressed in properly. A bad contact can cause overheating and fire.

- 25 Fit the lock clip over the connection. A click should be heard when the lock clip is fitted correctly.
- 26 Secure the heat protection on top of the electrical connection and pinch the ends of the heat protection.

**⚠ WARNING**

Make sure that the cable does not rest on sharp edges or hot surfaces. Damage from chafing and melting can cause a short circuit.

- 27 Fit the exhaust manifold's heat shield.

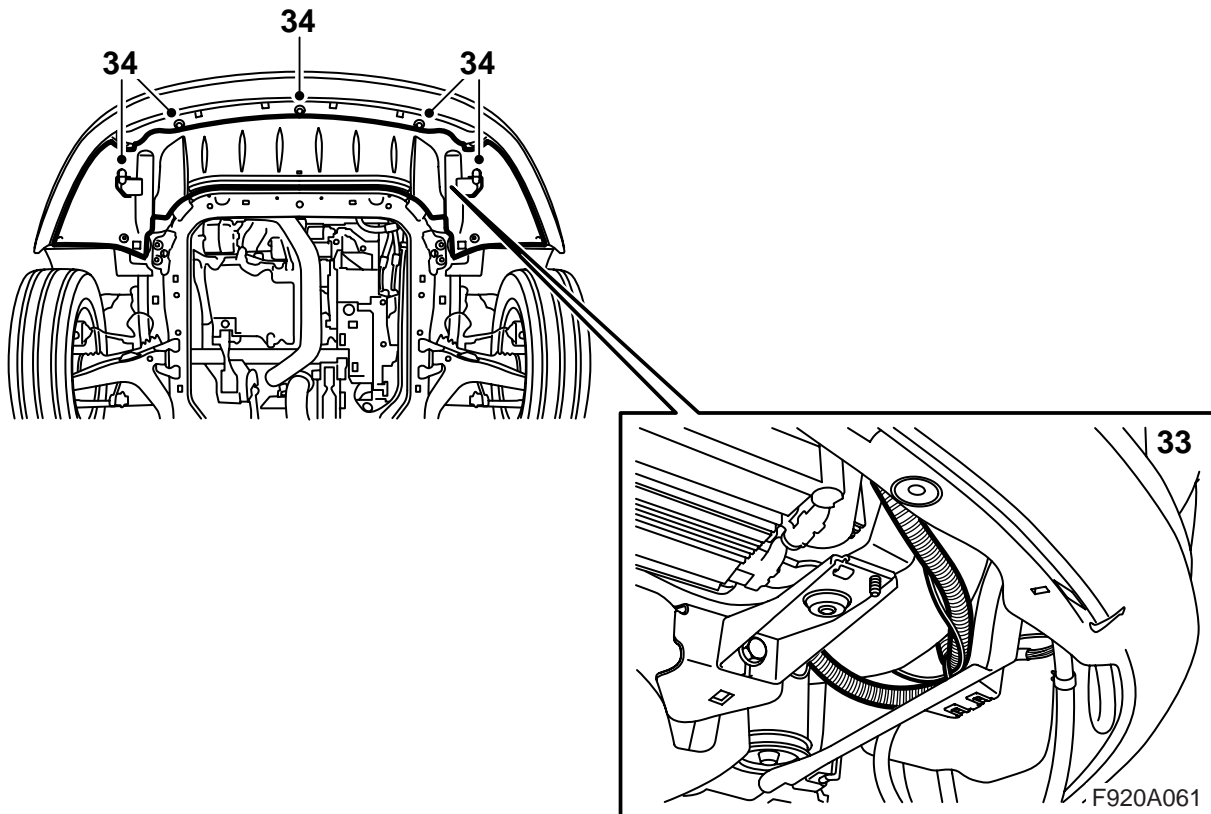

31 Bleed the cooling system in the following way:

### Note

The A/C or ACC should be turned OFF.

Fill the cooling system to MAX. Close the cap on the expansion tank, start the engine and run it warm at varying engine speeds.

Make sure there is a continuous flow of coolant from the hose leading from the thermostat housing to the expansion tank.

Run the engine until the thermostat opens.

Carefully open the cap on the expansion tank and top up to MAX. Close the cap. Turn off the engine and top up as necessary to MAX.

Turn off the engine, open the cap to the expansion tank carefully and top up to MAX. Close the cap.

32 Raise the car.

33 Secure the excess input cable between the lower left-hand bracket of the radiator and the plastic shield. Secure it with a cable tie.

34 Lift up the spoiler shield, fit the bumper connector into the holder and plug in the connector.

**Cars with headlamp washers:** Hook the hose onto the spoiler shield.

**All:** Fit the spoiler shield.

35 Lower the car.

36 **Cars with headlamp washers:** Check the operation of the headlamp washers.

## User instructions

- The extension cable must be made of oil-resistant rubber and approved for outdoor use with a cross-sectional area of at least  $3 \times 1.5 \text{ mm}^2$ .
- The heater system may only be connected to a grounded socket.
- Handle all cables with care. Pay particular attention to the risk of pinching between the bonnet and the body of the car and the risk of cuts on sharp metal components.

 **WARNING**

Check the ground connection between the connecting cable ground pin, the heater casing and the car body regularly to prevent electric shocks.

- Inspect regularly the extension cable for damage or ageing. Damaged cables must be renewed immediately.

### Note

The function of the heater will be at risk if:

- there are impurities in the coolant
- the coolant level is too low or if there is air in the system
- there is ice slush in the system
- radiator sealant is used