



**MONTERINGSANVISNING · INSTALLATION INSTRUCTIONS
MONTAGEANLEITUNG · INSTRUCTIONS DE MONTAGE**

Saab 9-5 B205E M07

Tuning Kit

Accessories Part No.	Group	Date	Instruction Part No.	Replaces
32 025 822 32 025 823 32 025 824	9:29-13	April 06	32 025 881	

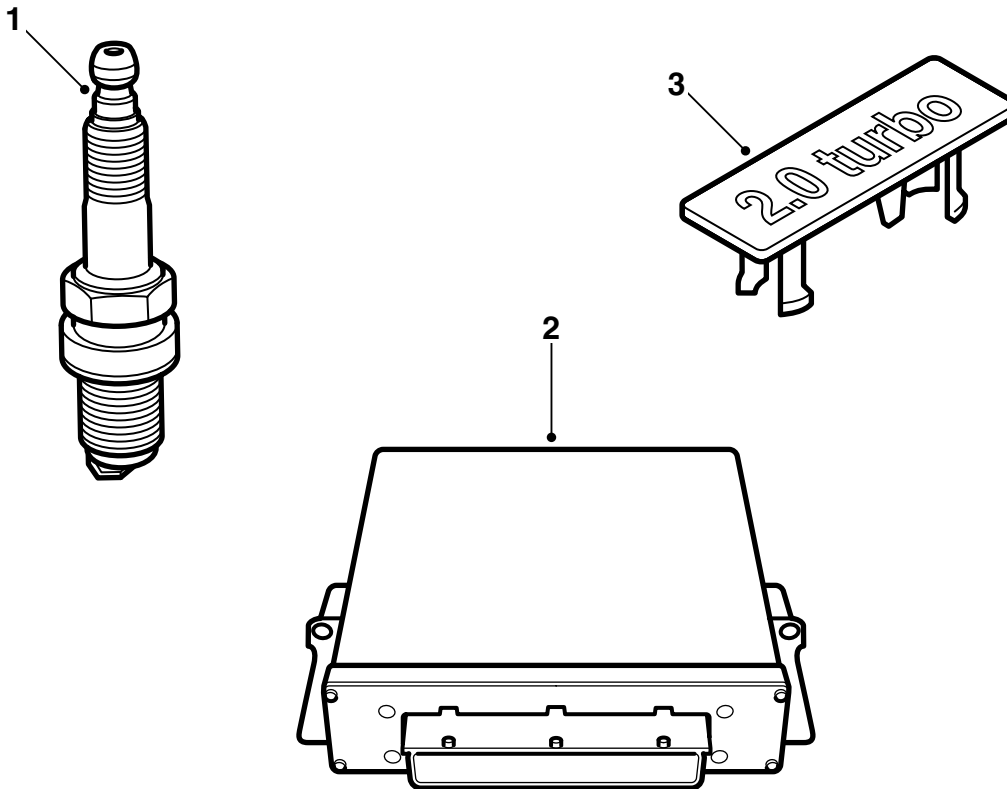

E920A017

- 1 Spark plugs (4 pcs.)
- 2 Control module
- 3 Emblem

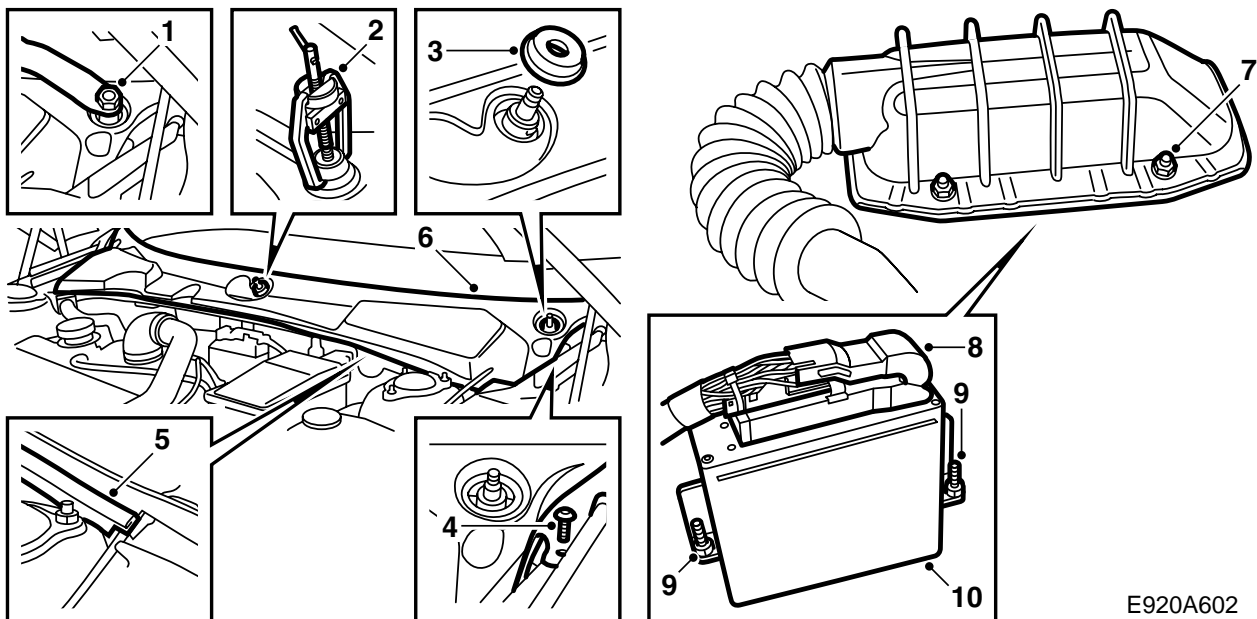

E920A602

- 1 Remove the covers over the nuts on the wiper spindles and loosen the nuts slightly.
- 2 Loosen the wiper arms with puller 85 80 144. Remove the nuts and wiper arms.
- 3 Remove the rubber wiper spindle seals.
- 4 Remove the two screw clips on the ends of the windscreen cover.
- 5 Loosen the rubber seal.
- 6 Remove the windscreen cover by gripping the front edge and lifting upwards/forwards. Pay attention to the hood (bonnet) release wire on the left-hand side.
- 7 Undo the 4 nuts securing the control module cover.
- 8 Tilt up the cover and unplug the control module connector by lifting up the catch on the right-hand side.
- 9 Undo the 2 control module retaining nuts. A 10 mm magnetic socket can be used.
- 10 Lift the control module straight up.

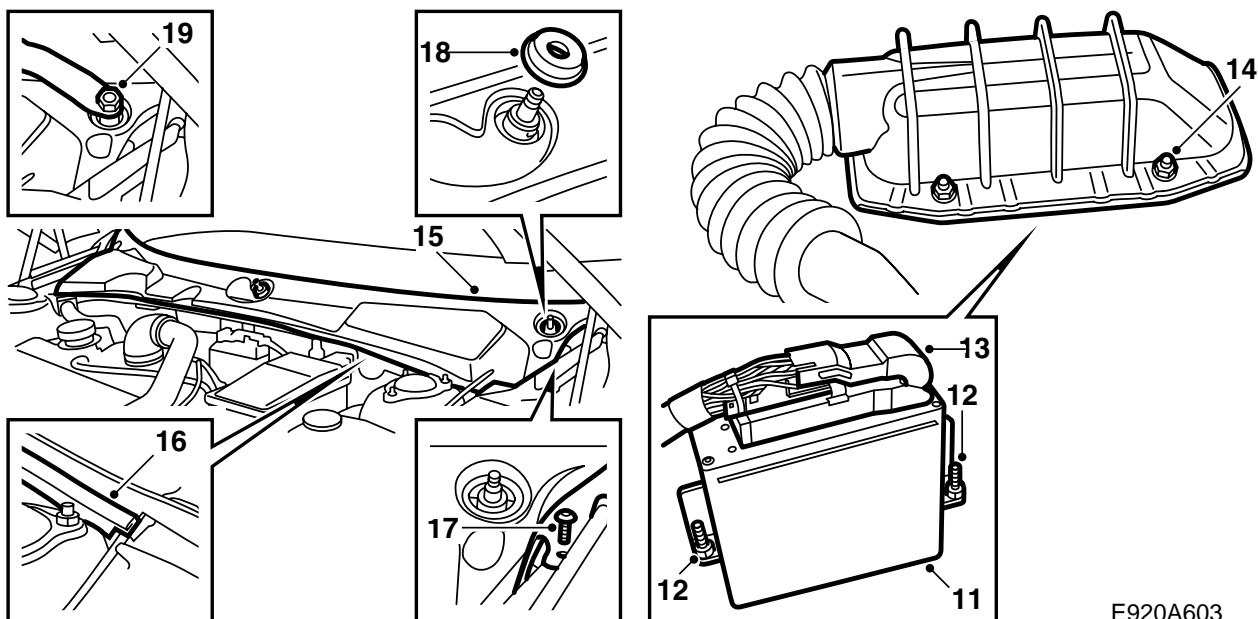

E920A603

- 11 Position the new control module.
- 12 Tighten the 2 control module retaining nuts.
- 13 Spray the control module multi-connector with Kontakt 61 (part no. 30 21 763), plug it in and secure it with the catch.
- 14 Fit the cover and tighten the 4 securing nuts.
- 15 Position the windscreen cover. Pay attention to the hood (bonnet) release wire on the left-hand side.
- 16 Fit the rubber seal.
- 17 Fit the two screw clips on the ends of the windscreen cover.
- 18 Refit the rubber wiper spindle seals.
- 19 Fit the wiper arms, adjust their resting position to the dot marks on the windscreen and tighten the nuts.
- 20 Refit the covers over the nuts on the wiper spindles.

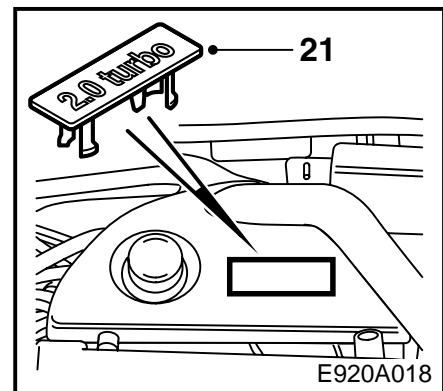
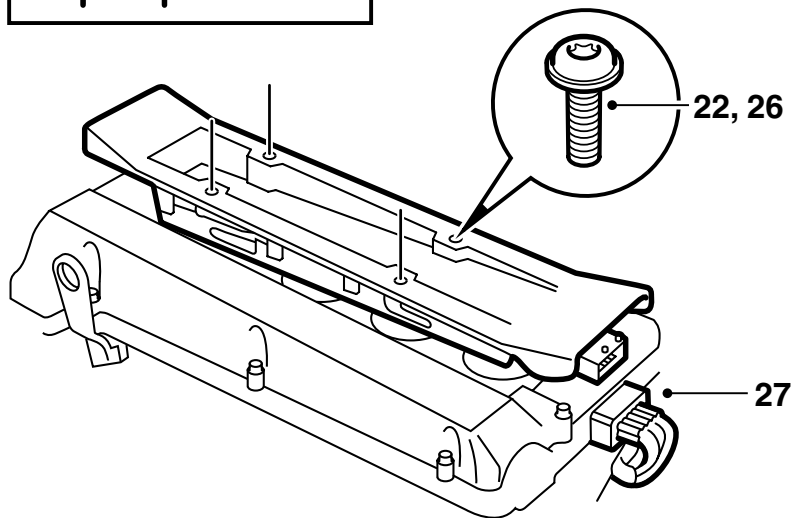
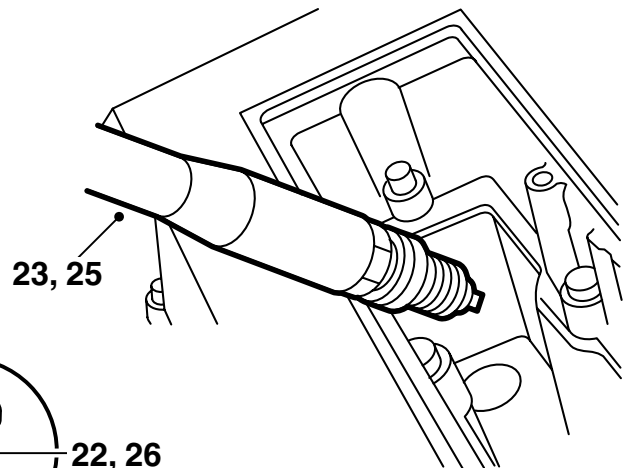
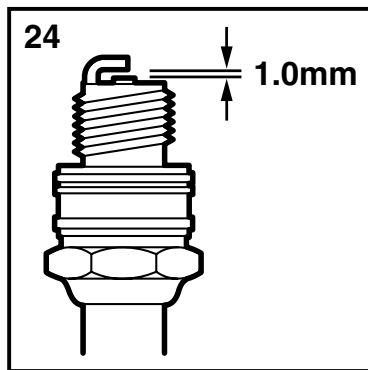

21 Remove the engine cover and the emblem from the cover. Fit the new emblem and refit the cover.

22 Unplug the ignition discharge module and unscrew the 4 bolts.

23 Remove the ignition discharge module and the spark plugs.

24 Check the new spark plug gaps. They should be 1.0-1.1 mm.

25 Apply Molykote 1000 (part no. 30 20 271) or equivalent to the threads on the new spark plugs and fit them the plugs.

Tightening torque: 27 Nm (20 lbf ft).

26 Lubricate the rubber seals on the ignition discharge module spark plug connections with Krytox (part no. 30 19 312) and fit the module.

Tightening torque: 11 Nm (8 lbf ft)

27 Plug in the connector to the ignition discharge module.

28 Program the control module with the TWICE control module and main instrument unit by connecting the diagnostic tool. Select TWICE and the "Immobilizer" menu and then select "Programming".

29 **Sweden:** Fill in the certificate included with the installation instructions and present it to the customer.

Important

A new registration test must be carried out on the car due to increased engine output.

The certificate must be presented at the new registration test.

30 Give these installation instructions and "TUNING KIT CERTIFICATE FOR SAAB 9-5" to the customer.

Important

There may be trouble codes present in the engine management system after programming. Clear them.



Handled by
TVKC Mats Åberg

Telefax
847 20

Date
2005-11-23

Our reference
TK 9-5 MY07 i1 (EU)

Direct dialling No.
859 65

Your date

Your reference

Tuning Kit certificate for Saab 9-5 2,0LPT with Manual or Automatic gearbox from year model 2007

We hereby certify that a car equipped with Tuning Kit, part number 32 02 5824, is covered by the European Whole Vehicle Type Approval number e4*2001/116*0096*01 and future extensions as long as the Tuning Kit is suitable to fit from homologation point of view.

Engine code	B205E/TK
Manual gearbox code	FM55
Automatic gearbox code	FA57
Maximum net power	136 kW (185 bhp) at 5500 rpm

Saab Automobile AB
Manager Safety and Regulatory Affairs

Torbjörn Svensson



Handled by
TVKC Mats Åberg

Telefax
847 20

Date
2005-11-23

Our reference
TK 9-5 MY07 11 (GE

Direct dialling No.
859 65

Your date

Your reference

Tuning Kit certificate for Saab 9-5 2,0LPT with Manual gearbox from year model 2007

We hereby certify that a car equipped with Tuning Kit, part number 32 02 5823, is covered by the European Whole Vehicle Type Approval number e4*2001/116*0096*01 and future extensions as long as the Tuning Kit is suitable to fit from homologation point of view.

Engine code	B205E/FC/TK
Manual gearbox code	FM57
Maximum net power	136 kW (185 bhp) at 5500 rpm

Saab Automobile AB
Manager Safety and Regulatory Affairs



Torbjörn Svensson

KONVERTERINGSLISTA SAAB 9-5 2,0t, M07 -

Motorutförande B205E/TK med trimningsats,
art. nr. 32 02 5824

Modellår	2007 -
Motoreffekt, EEC	136 kW (185 hk)/ 5500 rpm
Max. vridmoment, EEC	280 Nm/ 2500 rpm
Elektronikenhet, T7	55 56 3154
Tändstift	NGK PFR 6H-10
Emblem 2,0 Turbo	14 96 8343
Monteringsanvisning trimsats	32 025 881

INTYG

Saab Automobile AB har tillverkat följande personvagn:

Typbeteckning: _____
Chassinummer: _____
Årsmodell: _____

Fordonet har utrustats med av Saab Automobile AB utprovad och specificerad trimningsats för motor B205E/TK, M07 -.

Härmed intygas att inbyggnad och specifikation avseende ovan nämnda fordon i konverterat utförande är helt i överensstämmelse med av Saab Automobile AB utfärdade anvisningar och därtill hörande Konverteringslista. Fordonet överensstämmer med europeiskt helbils-godkännande nr: e4*2001/116*0096*01 och är miljöklassad enligt: Miljöklass 2005.

Undertecknad firma är av Saab Automobile AB aukt. verkstad och delegerad att utfärda detta intyg, som skall uppvisas vid registreringsbesiktning hos Bilprovningen på grund av ändrad motoreffekt.

Ort och datum: _____

Verkmästare: _____

Firmastämpel: