

**SAAB****MONTERINGSANVISNING · INSTALLATION INSTRUCTIONS
MONTAGEANLEITUNG · INSTALLATIONS DE MONTAGE**

Saab 900 M94-, Saab 9000 M85-

Wiring harness, signal monitoring, towbar installation

Accessories Part No.	Group	Date	Instruction Part No.	Replaces
400 101 259	3:71-14	Apr 99	86 79 292	750414 Jul 93

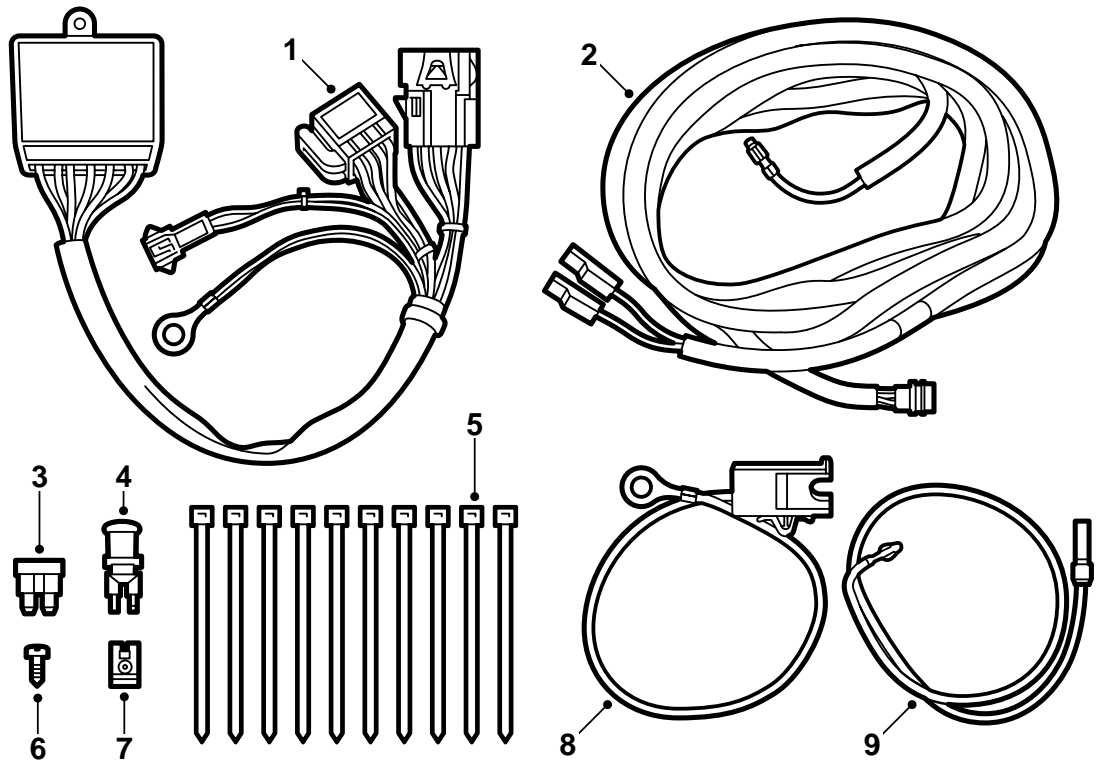

D930A102

The kit contains

- 1 Control module
- 2 Wiring
- 3 Fuse, 5 A
- 4 Lamp and holder
- 5 Cable ties (10)
- 6 Screw
- 7 Clips
- 8 Fuse holder
- 9 Fog light wiring

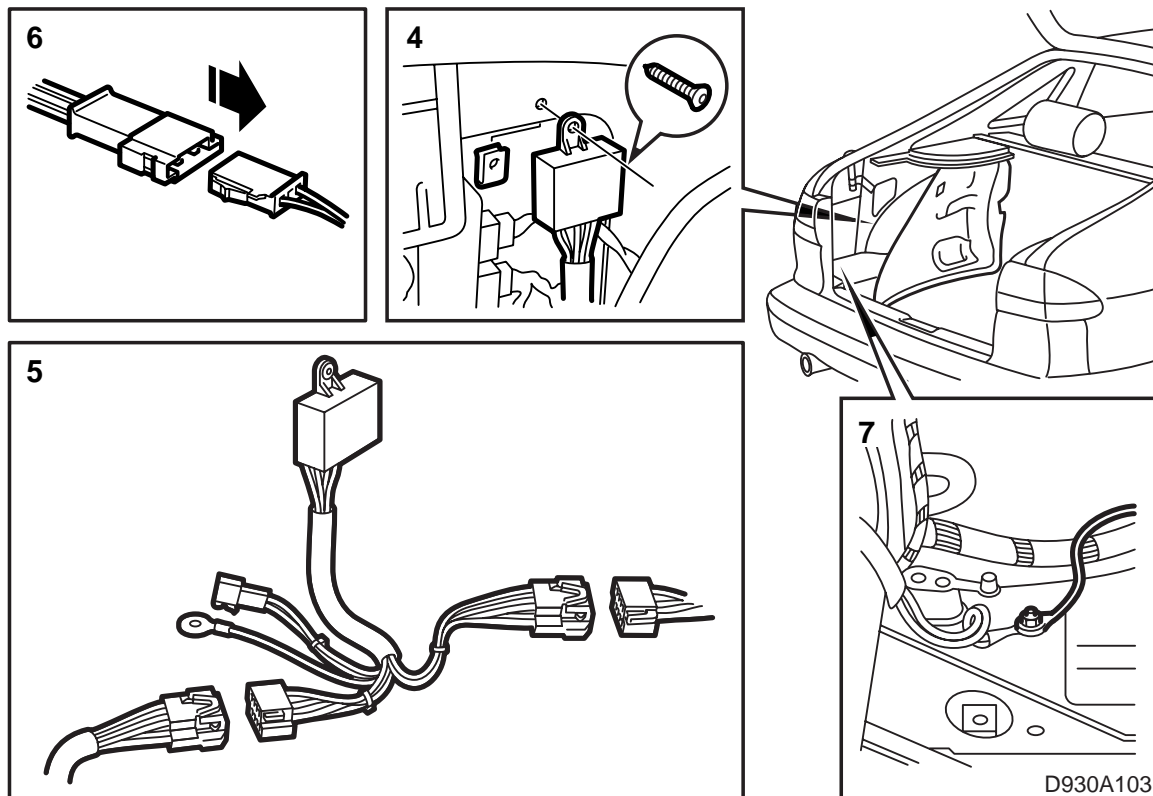

Saab 900 M94-

- 1 Disconnect the negative battery cable.
- 2 Remove the left-hand rear side trim in the luggage compartment and the cover below the dashboard. Also remove the sill scuff plates on the left-hand side.
RHD : Remove the glove box.
3-D : Remove the rear seats's left-hand side trim at the bottom.
- 3 Fold the rear seat forwards.
- 4 Mount the control module on the inner panel in the luggage compartment, on the left-hand side next to the aerial/electric aerial.
- 5 Fit the connectors to the car's control wiring or prepared wiring and also to the wiring from the towing attachment.
- 6 Fit the 3-pin connector to the wiring for the positive supply and the pilot lamp.
- 7 Connect the ground cable to the grounding point below the left-hand rear light cluster.

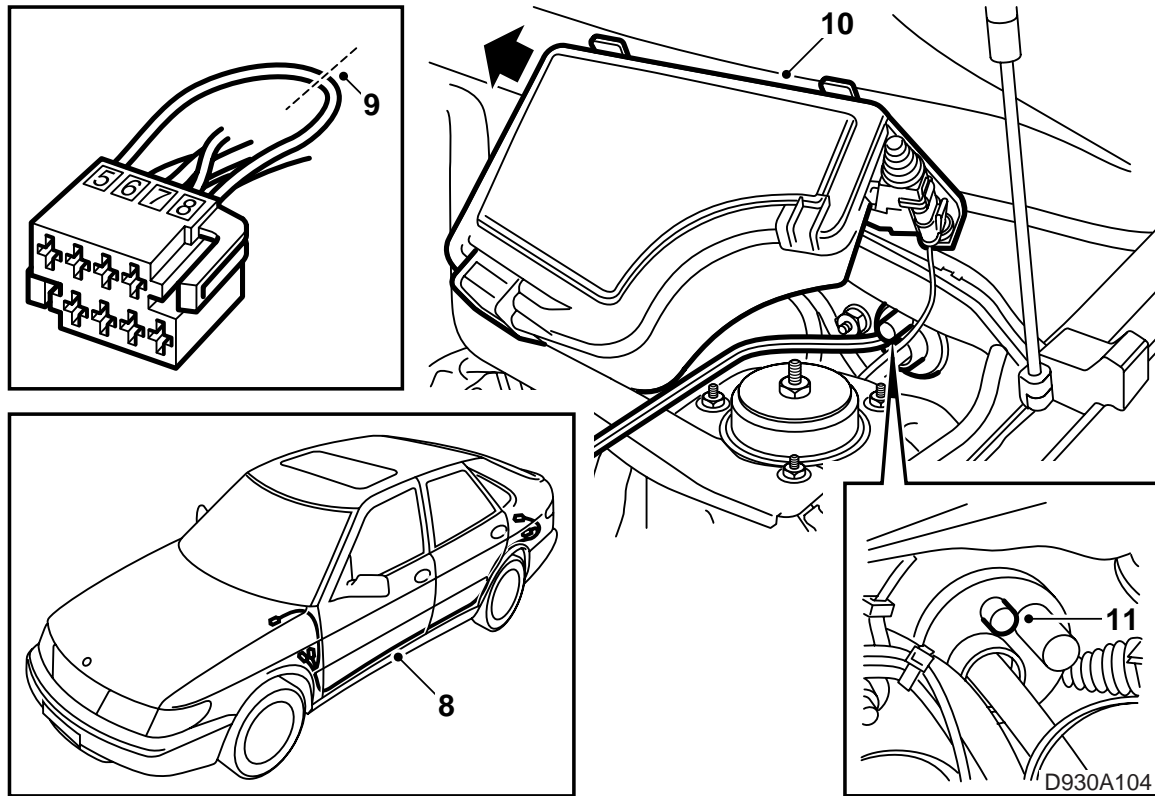

Saab 900 M94-

- 8 Run the wiring for the positive supply alongside the car's main wiring harness on the left-hand side and fix the wiring by means of cable ties.
- 9 Snip through the jumper connection between pins 5 and 8 in the 8-pin connector below the left-hand rear light cluster.
- 10 Remove the steady bar in the engine bay and lift up the large main fuse box in the engine bay.
- 11 Cut through one of the small rubber grommets in the bulkhead leading into the cabin.
- 12 Remove the knee shield and air duct.

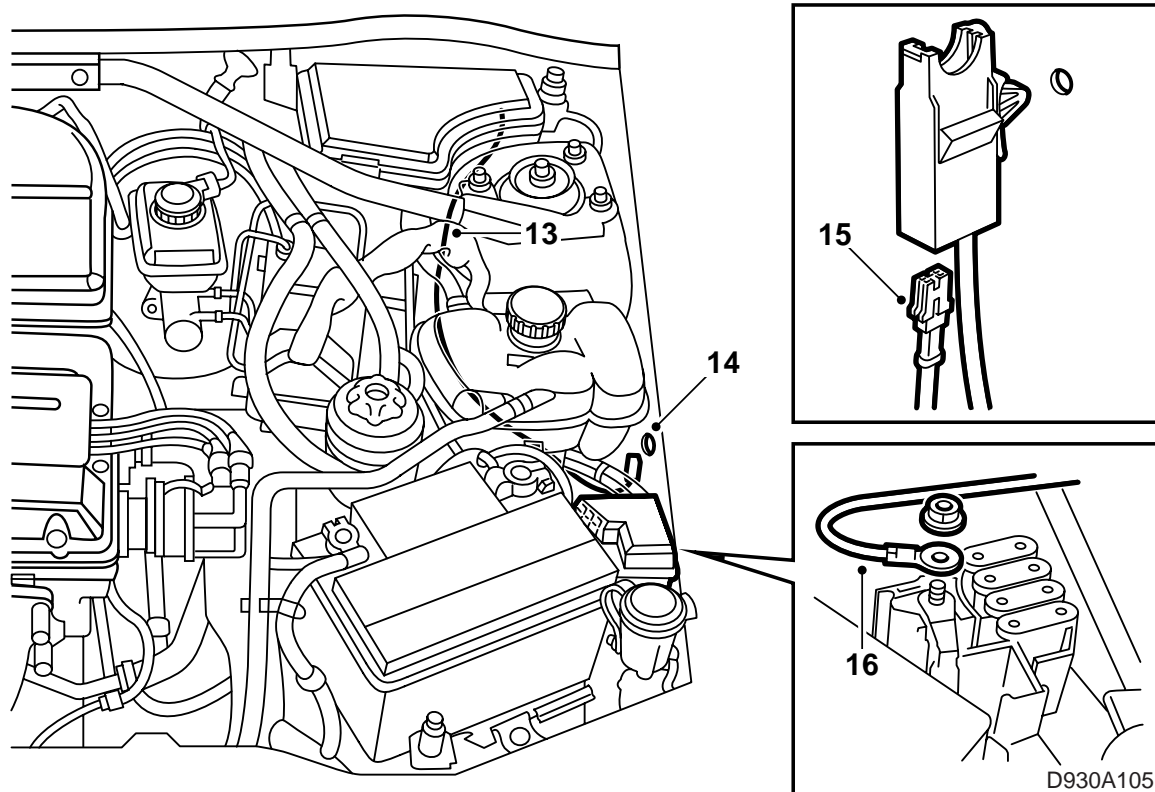
**Saab 900 M94-**

- 13 Using a length of steel wire, pull the RED cable into the engine bay.
- 14 Drill an 8 mm hole in the left-hand structural member near the Maxi fuse holder.
Apply anti-rust agent to the hole and press the fuse holder into place.
- 15 Run the wiring under the expansion tank and connect the cable to the fuse holder.
- 16 Connect the RED cable from the fuse holder to the positive terminal for the Maxi fuses.

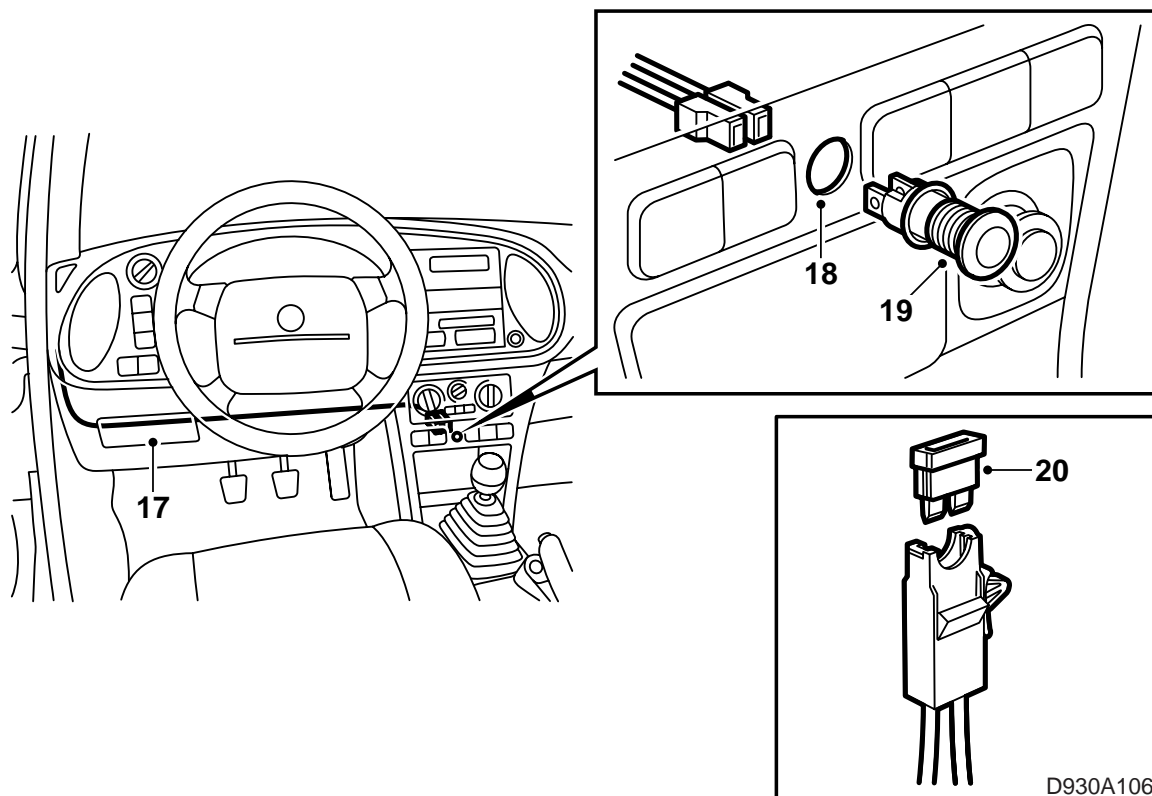
**Saab 900 M94-**

- 17 Run the wiring for the lamp to the centre console (making sure that it does not come into contact with any moving parts (LHD)).
- 18 Drill an 11,5 mm hole in the centre console where it can be plainly seen by the driver.
- 19 Fit the lamp by means of clips at the rear and fix the wiring with cable ties.
- 20 Fit a 5 A fuse in the fuse holder in the engine bay.
- 21 Check that operation is satisfactory.
- 22 Refit all parts that have been removed.

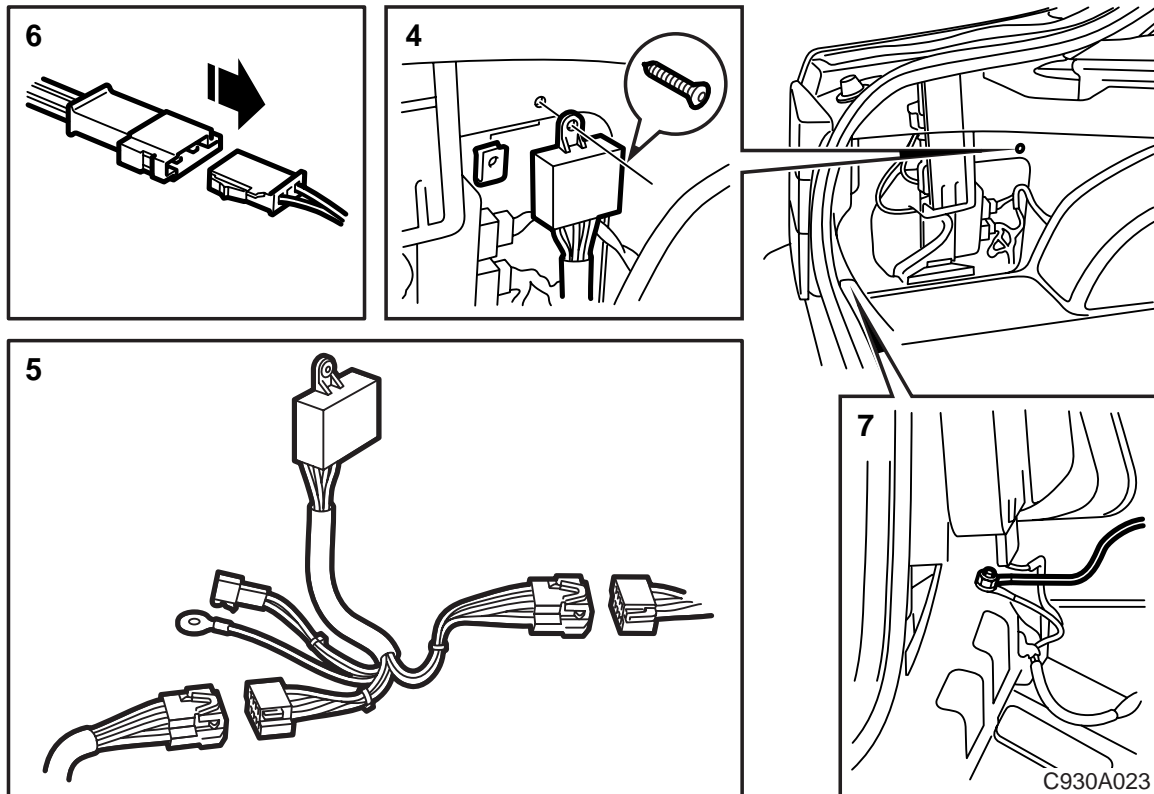

Saab 9000 M85-

- 1 Disconnect the negative battery cable.
- 2 Remove the left-hand rear side trim in the luggage compartment and the cover below the dashboard. Also remove the sill scuff plates on the left-hand side.
RHD : Remove the glove box.
- 3 Remove the backrest (CD).
- 4 Mount the control module on the inner panel in the luggage compartment, on the left-hand side next to the aerial/electric aerial.
- 5 Fit the connectors to the car's prepared wiring and also to the wiring from the towing attachment.
- 6 Fit the 3-pin connector to the wiring for the positive supply and the pilot lamp.
- 7 Connect the ground cable to the grounding point below the left-hand rear light cluster.

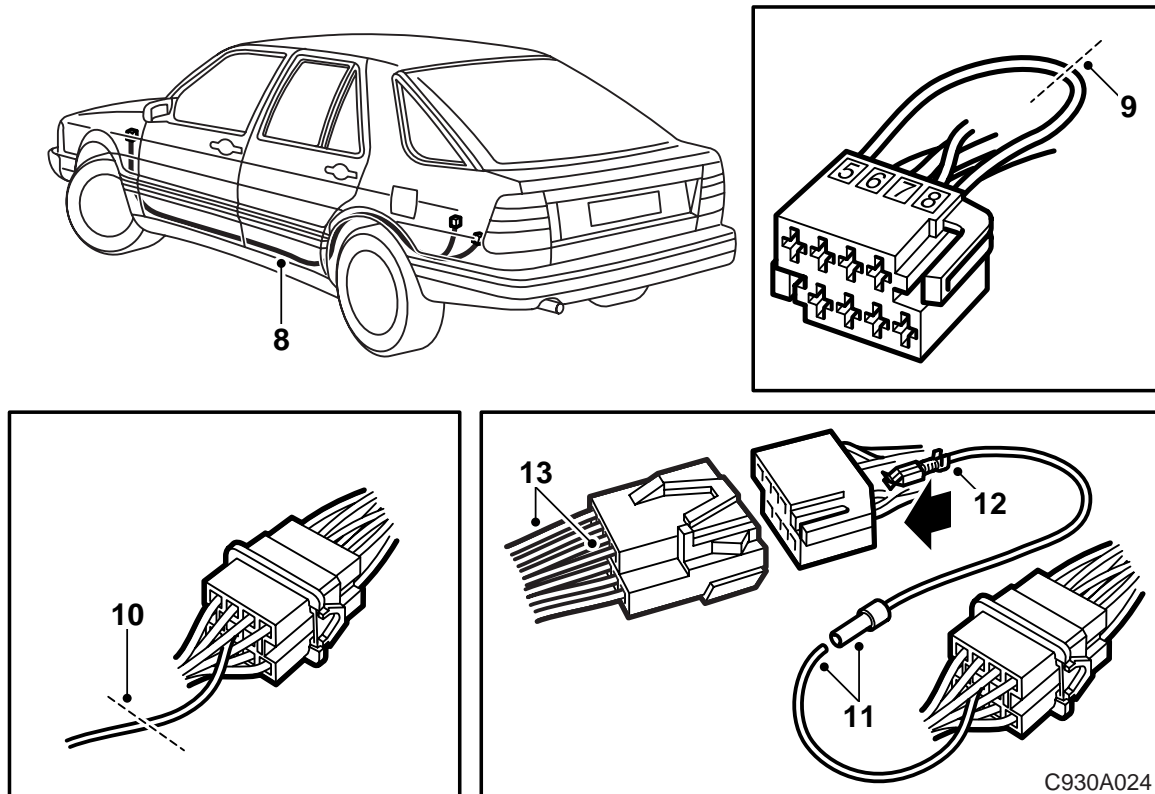

Saab 9000 M85-

- 8 Run the wiring for the positive supply alongside the car's main wiring harness on the left-hand side and fix it by means of cable ties.
- 9 Cut through the jumper connection between pins 5 and 8 in the 8-pin connector below the left-hand rear light cluster in the luggage compartment.
- 10 **M92-M93:** Cut the thick blue cable off pin 10 in the connector by the left-hand rear wheel housing.
- 11 Fit and crimp the tubular sleeve in place on the "DIM" wiring in the kit.
- 12 Remove pin 8 from the prepared wiring harness and cut off the lead. Connect the "DIM" wiring.
- 13 Transpose pins 5 and 8 in the 8-pin male connector.

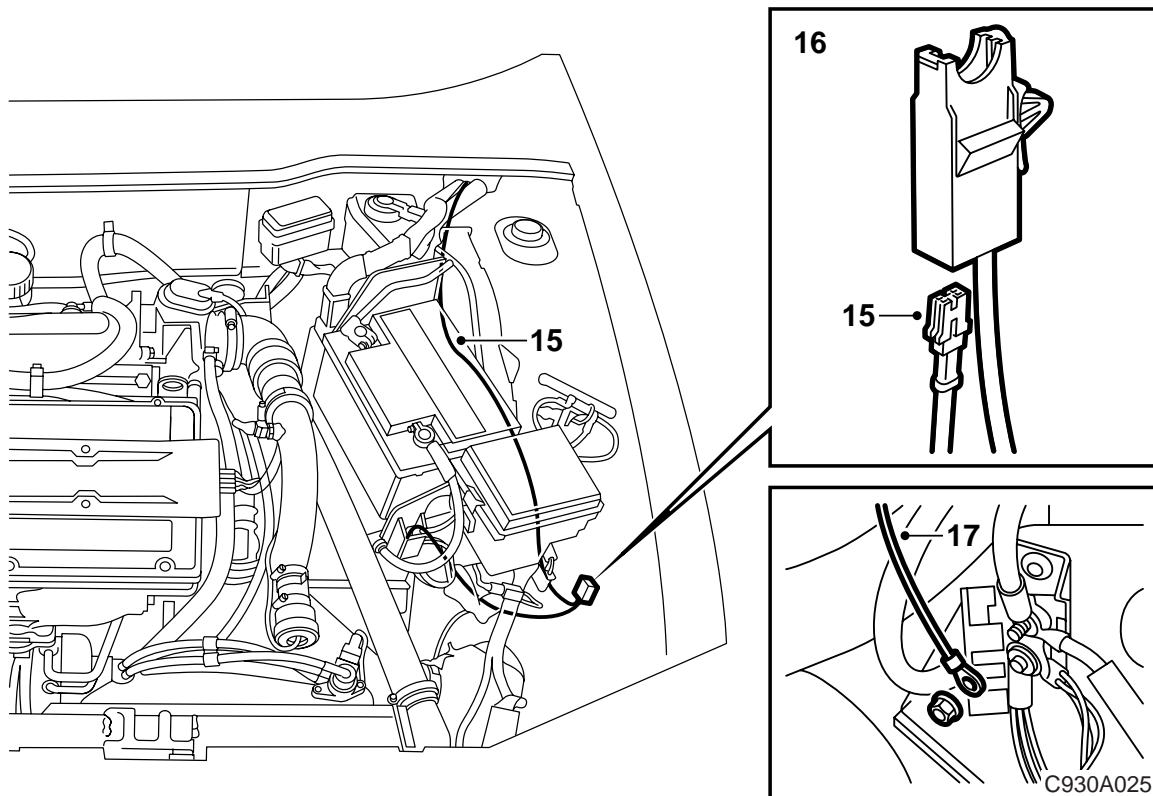

Saab 9000 M85-

- 14 Remove the knee shield and air duct.
- 15 Pull the RED cable into the engine bay, using a length of steel wire, by the brake cylinder.
- 16 Drill an 8 mm hole in the left-hand structural member near the terminal block on the battery tray.
Apply anti-rust agent to the hole and press the fuse holder into place.
- 17 Connect the RED cable from the fuse holder to the terminal block on the battery tray.

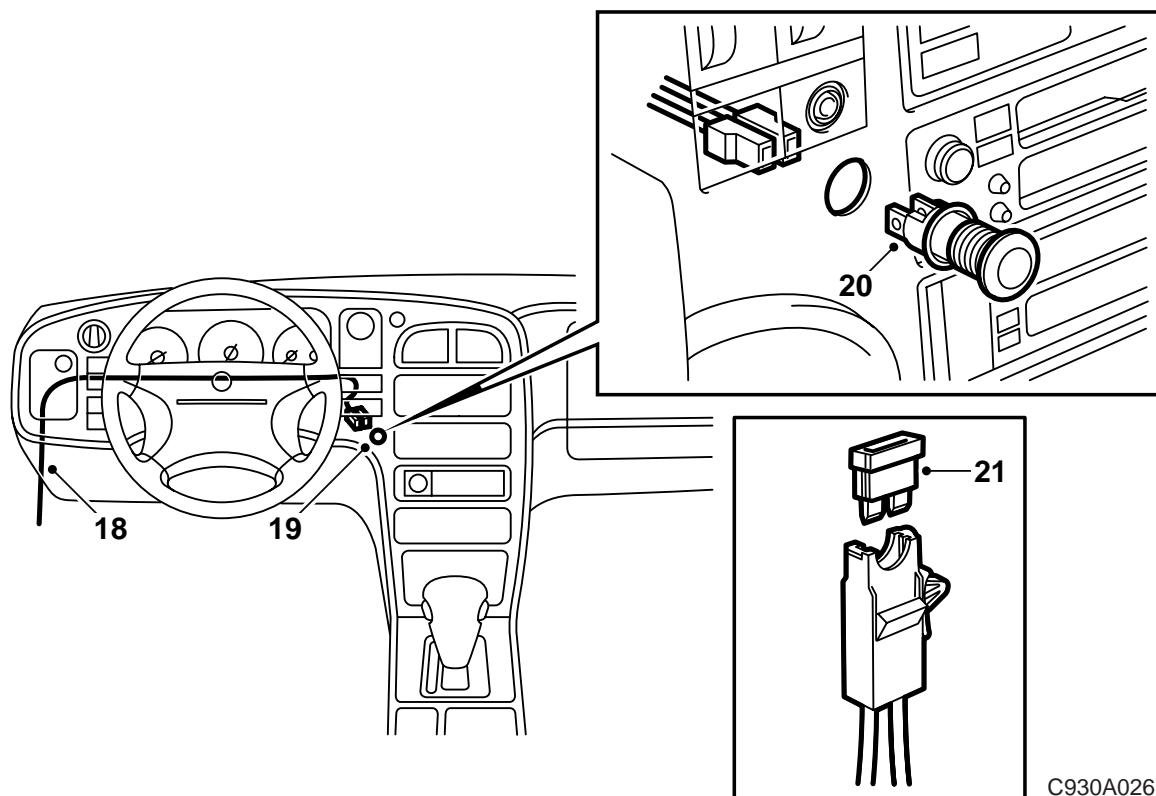

C930A026

Saab 9000 M85-

- 18 Run the wiring for the lamp to the centre console (making sure that it does not come into contact with any moving parts (LHD)) or to the side of the panel on the left of the steering wheel.
- 19 Drill an 11.5 mm hole in the centre console where it can be plainly seen by the driver.
- 20 Fit the lamp by means of clips at the rear and fix the wiring with cable ties.
- 21 Fit a 5 A fuse in the fuse holder in the engine bay.
- 22 Check that operation is satisfactory.
- 23 Refit all parts that have been removed.

Wiring diagram, fog light and direction indicator monitoring

