

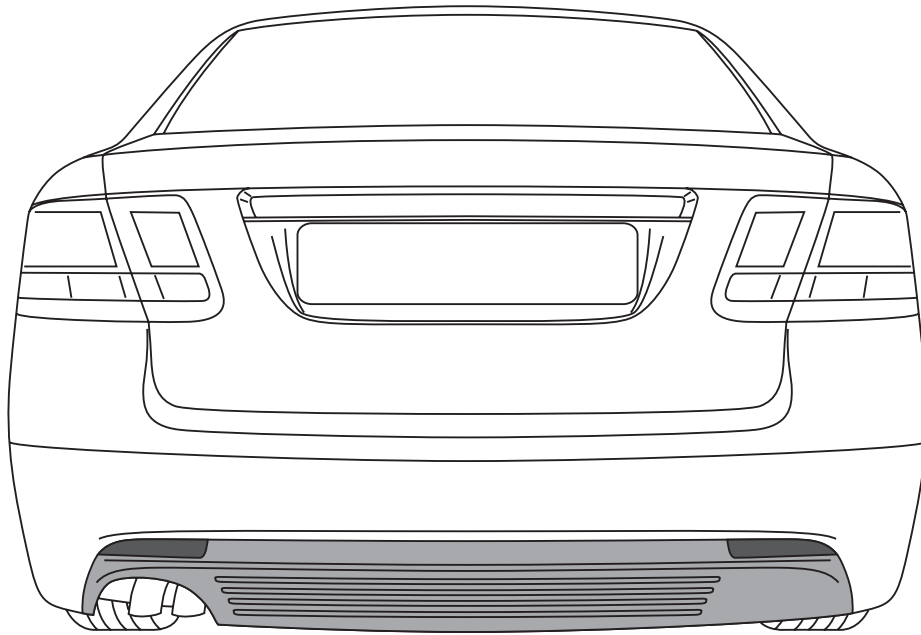

**MONTERINGSANVISNING • INSTALLATION INSTRUCTIONS  
MONTAGEANLEITUNG • INSTRUCTIONS DE MONTAGE**

Accessories Part No.	Date	Instruction Part No.	Replaces
<b>32 025 847</b>	<b>May 2007</b>	<b>32 026 187</b>	

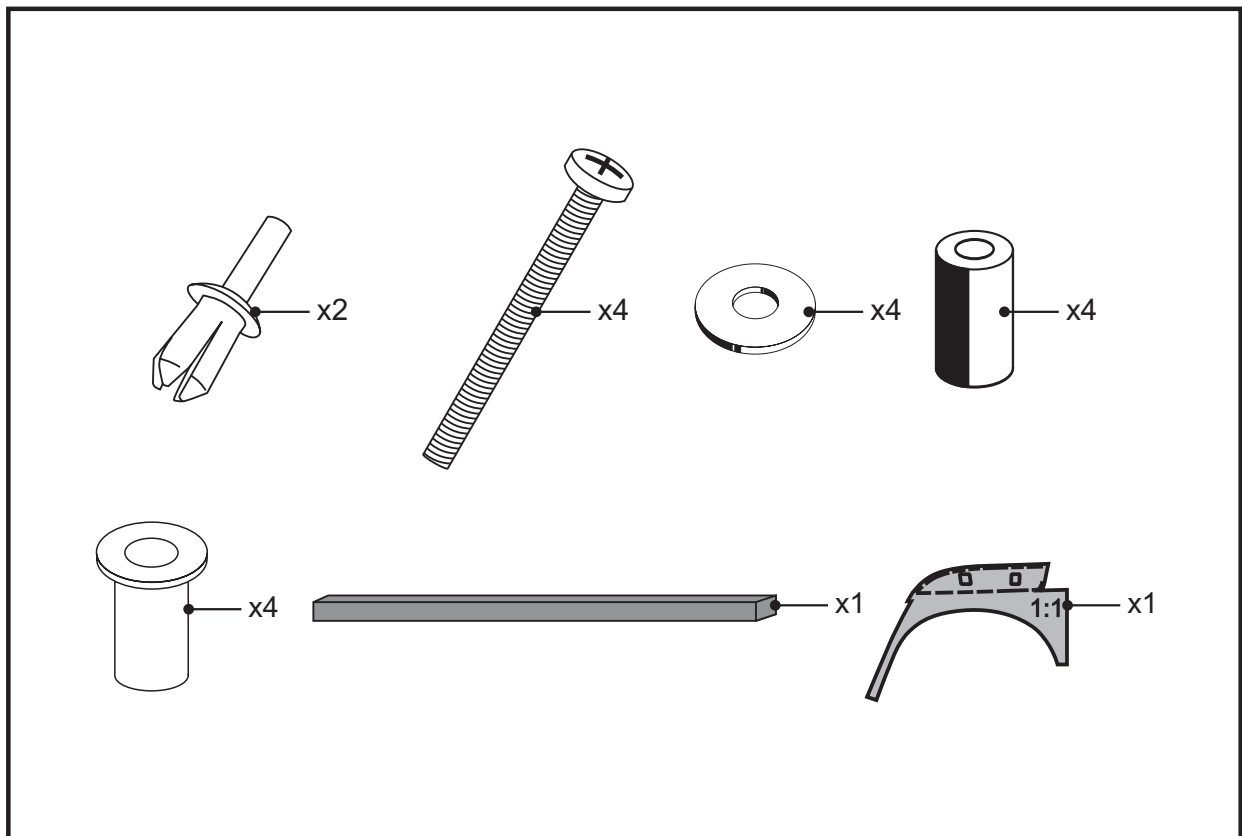

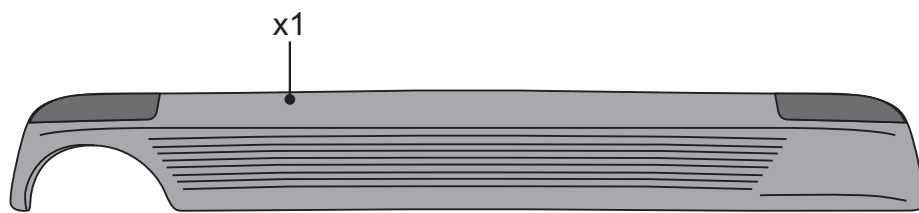

## Importante

### **ATENCIÓN**

Lea cuidadosamente las instrucciones de instalación antes de usar el accesorio.

Estas instrucciones de instalación deben almacenarse en el coche.

En caso de duda, contacte con su concesionario más cercano.

¡No conduzca el coche en las 5 horas posteriores a la instalación de la pieza!

¡No conduzca el coche a una velocidad alta (más de 100 km/h) en las 24 horas posteriores a la instalación de la pieza!

¡No lave su coche en un túnel de lavado automático en las 48 horas posteriores a la instalación de la pieza!

---

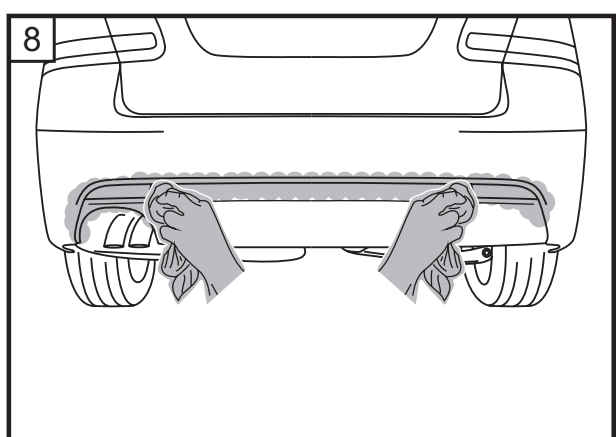
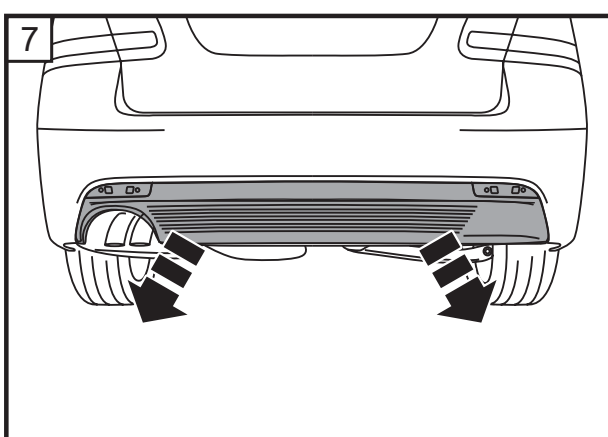
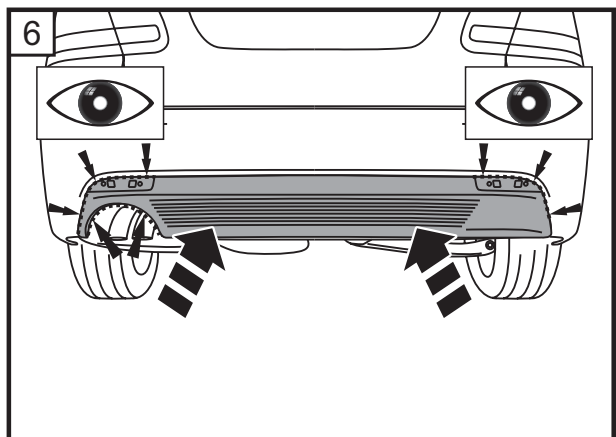
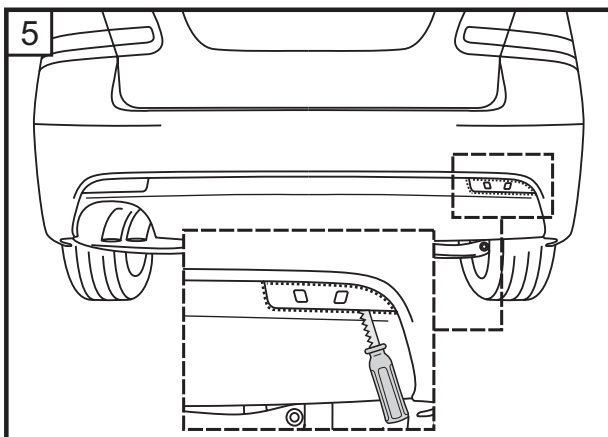
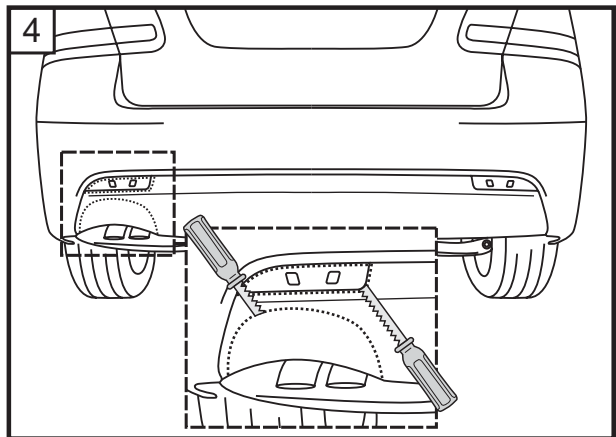
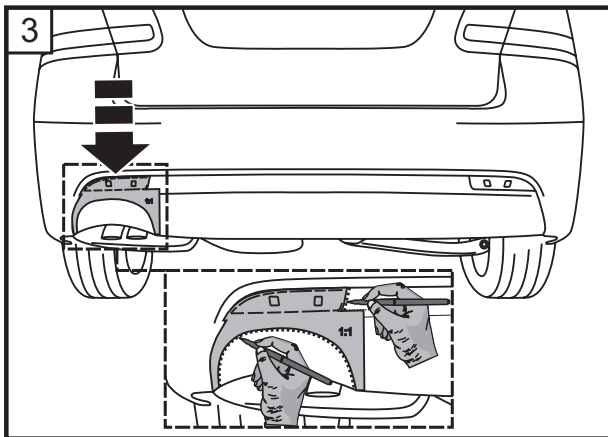
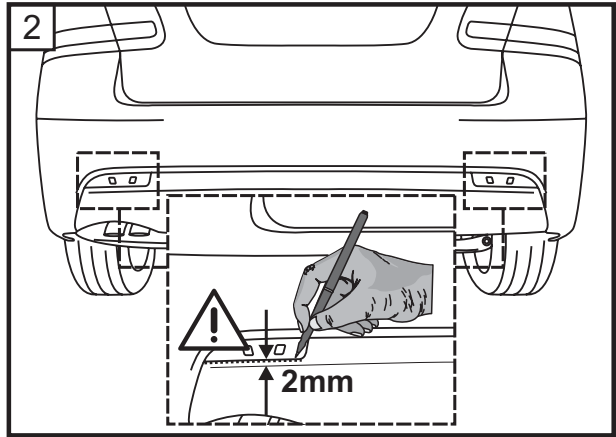
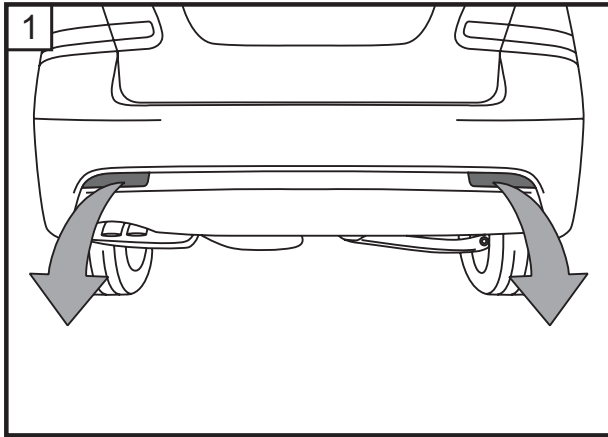

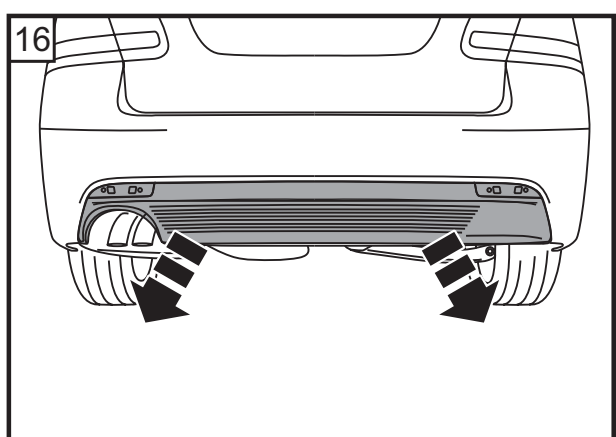
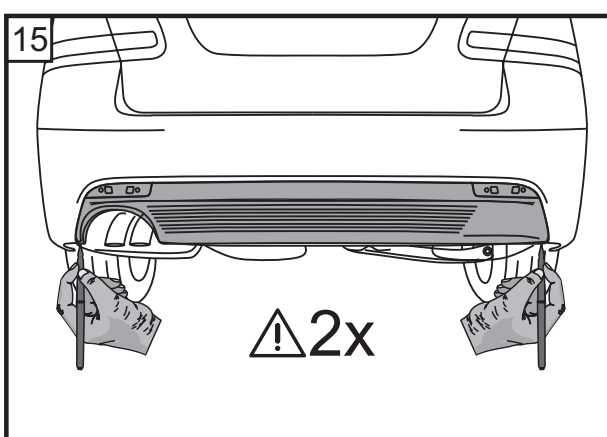
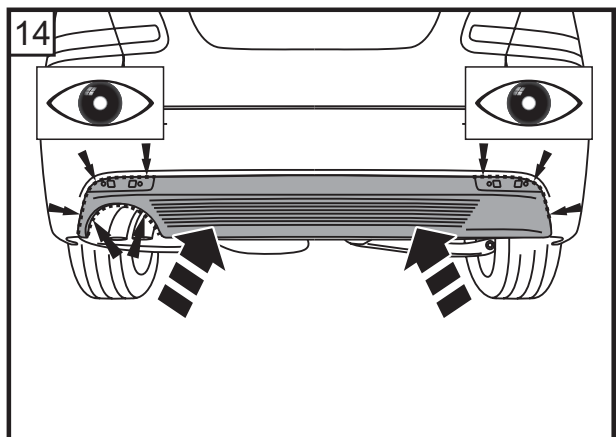
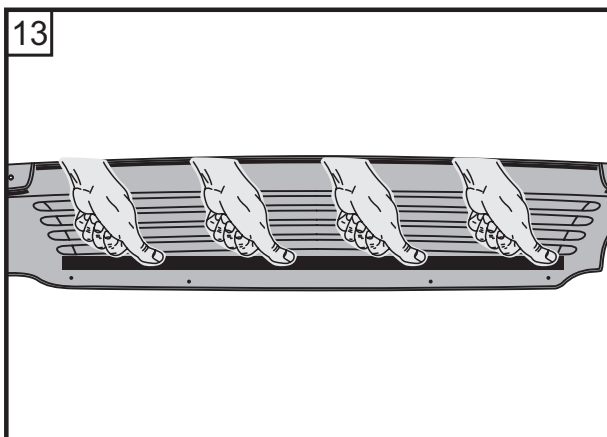
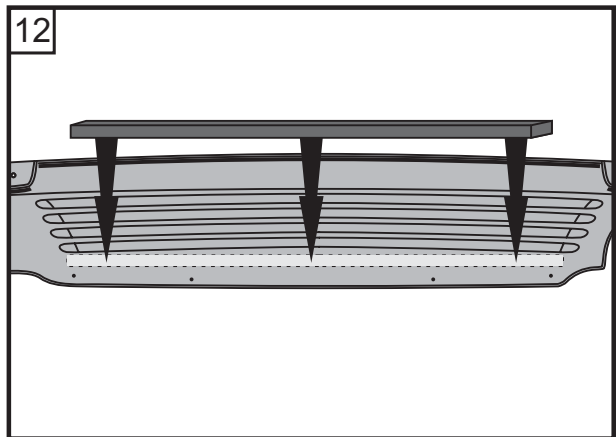
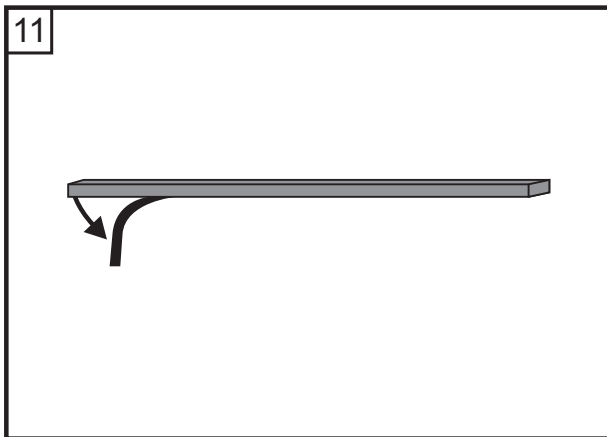
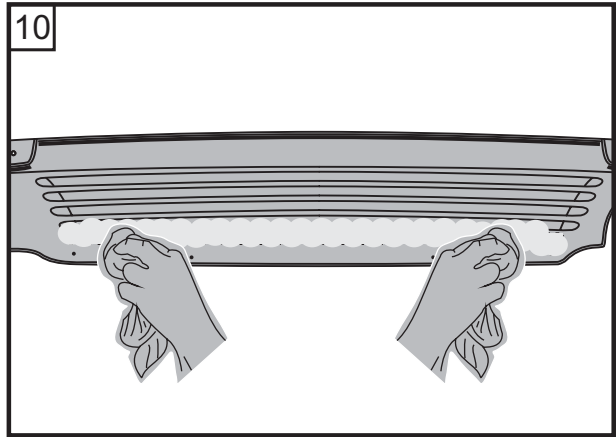
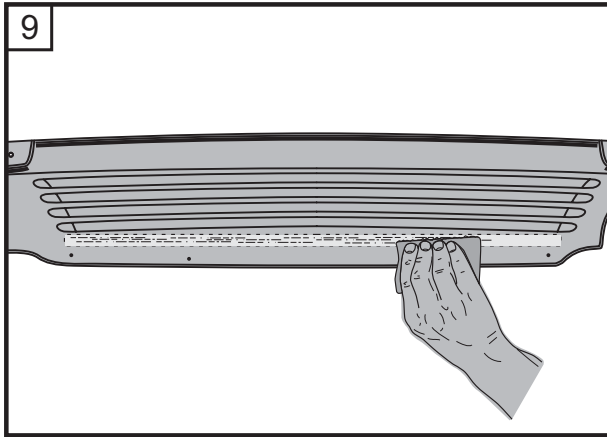

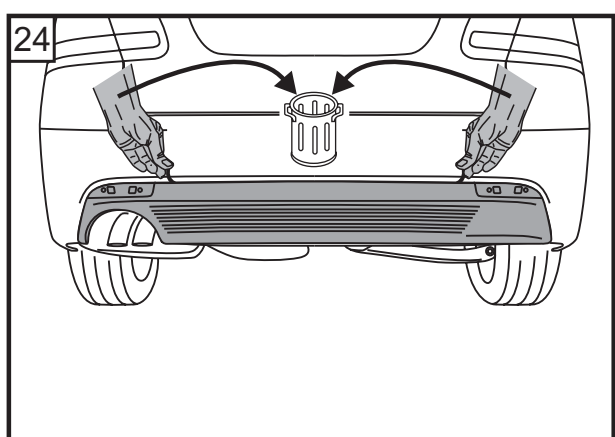
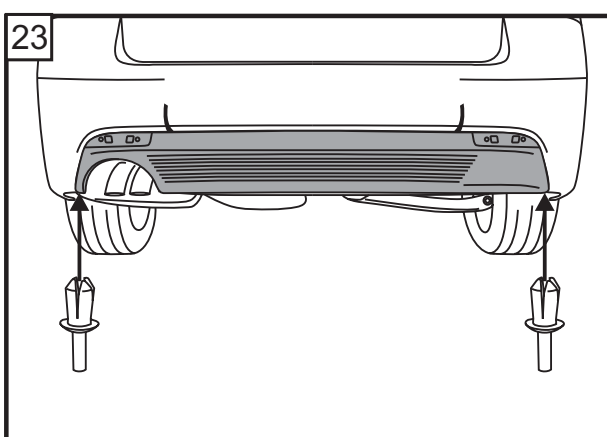
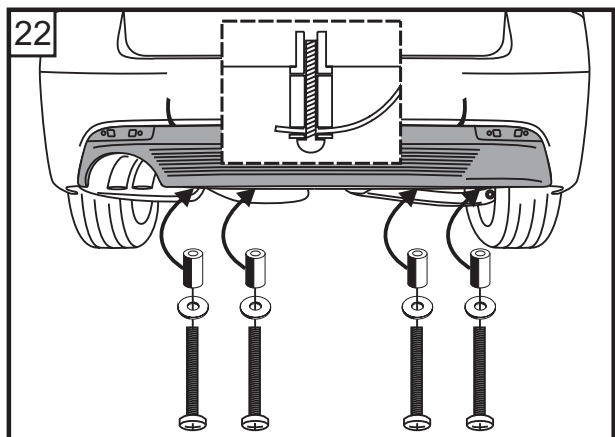
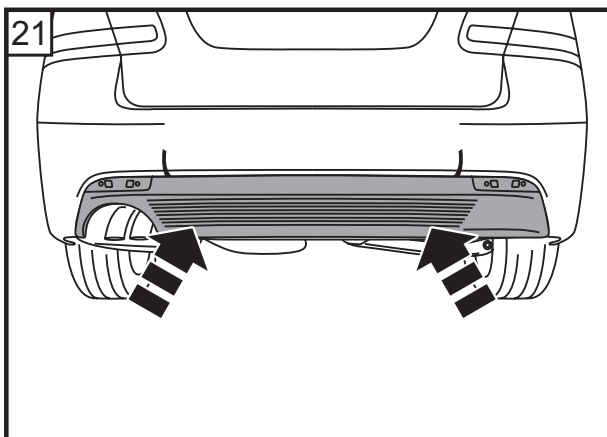
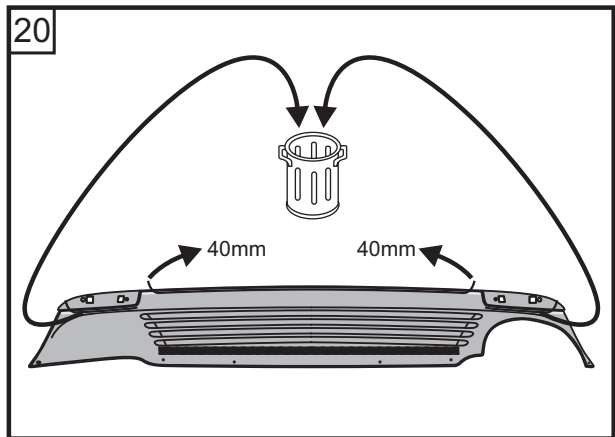
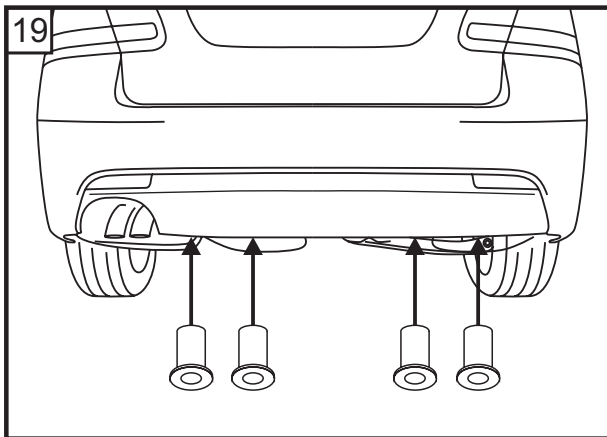
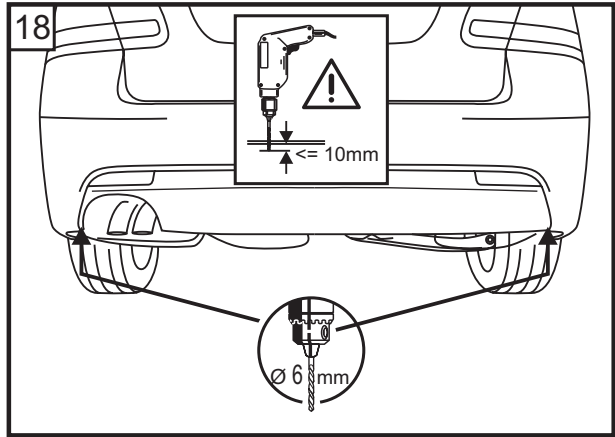
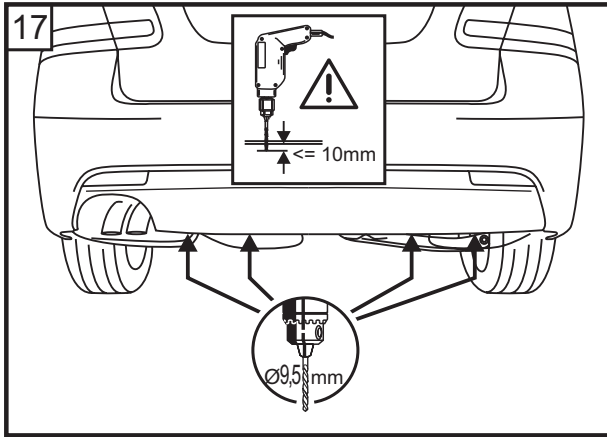

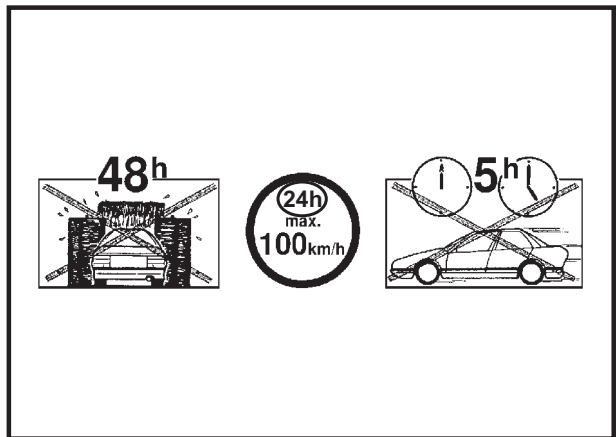
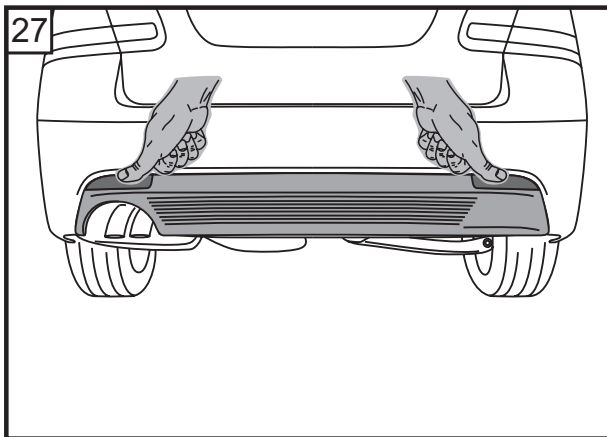
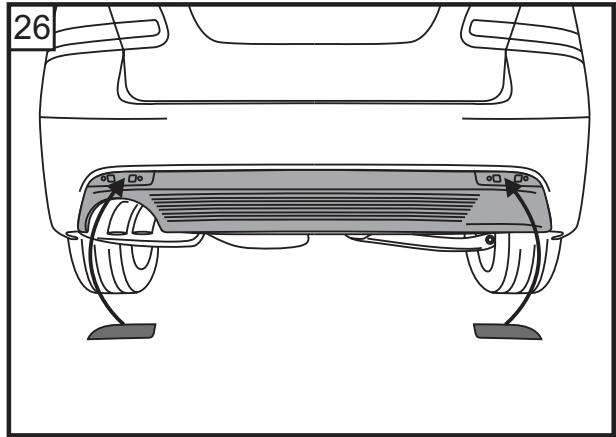
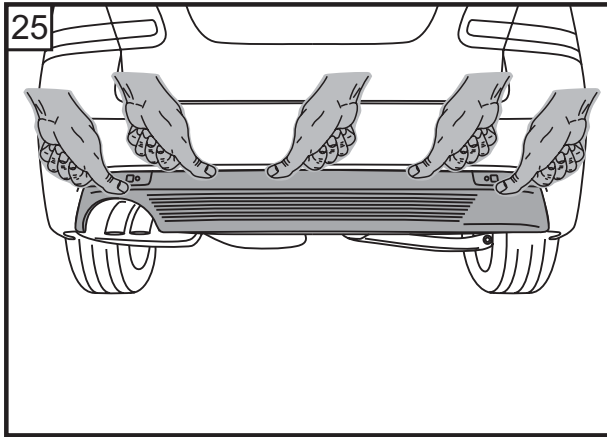





## Instrucciones de pintado para piezas imprimadas

<b>ES</b>		Pula el componente imprimado con suavidad (P800-P1000). Evite pulir la capa de imprimación base.
		Verifique los puntos defectuosos, repárelos y pula las zonas reparadas con suavidad (P800-P1000). Vuelva a imprimir los puntos que han sido pulidos utilizando una capa de imprimación plástica adecuada.
		Limpie a fondo utilizando un producto para eliminar la silicona.
		Es importante garantizar que el componente se encuentra correctamente apoyado durante el proceso de pintado (¡existe riesgo de deformación!) Pinte siguiendo la técnica de aplicación y concentración de conformidad con el fabricante de la pintura; los aditivos que confieren elasticidad especificados por el fabricante de la pintura son de especial importancia. La denominación del material se encuentra en el interior del componente (>.....<, z.B. >PUR-MF15<).
		<b>¡No calentar la pintura (máximo 40 °C)!</b>