



MONTERINGSANVISNING · INSTALLATION INSTRUCTIONS
MONTAGEANLEITUNG · INSTRUCTIONS DE MONTAGE

Saab 9-3 B207 M03-

Engine block heater

Accessories Part No.	Group	Date	Instruction Part No.	Replaces
12 788 906	9:87-36	Oct 02	12 788 907	12 788 907 Mar 02

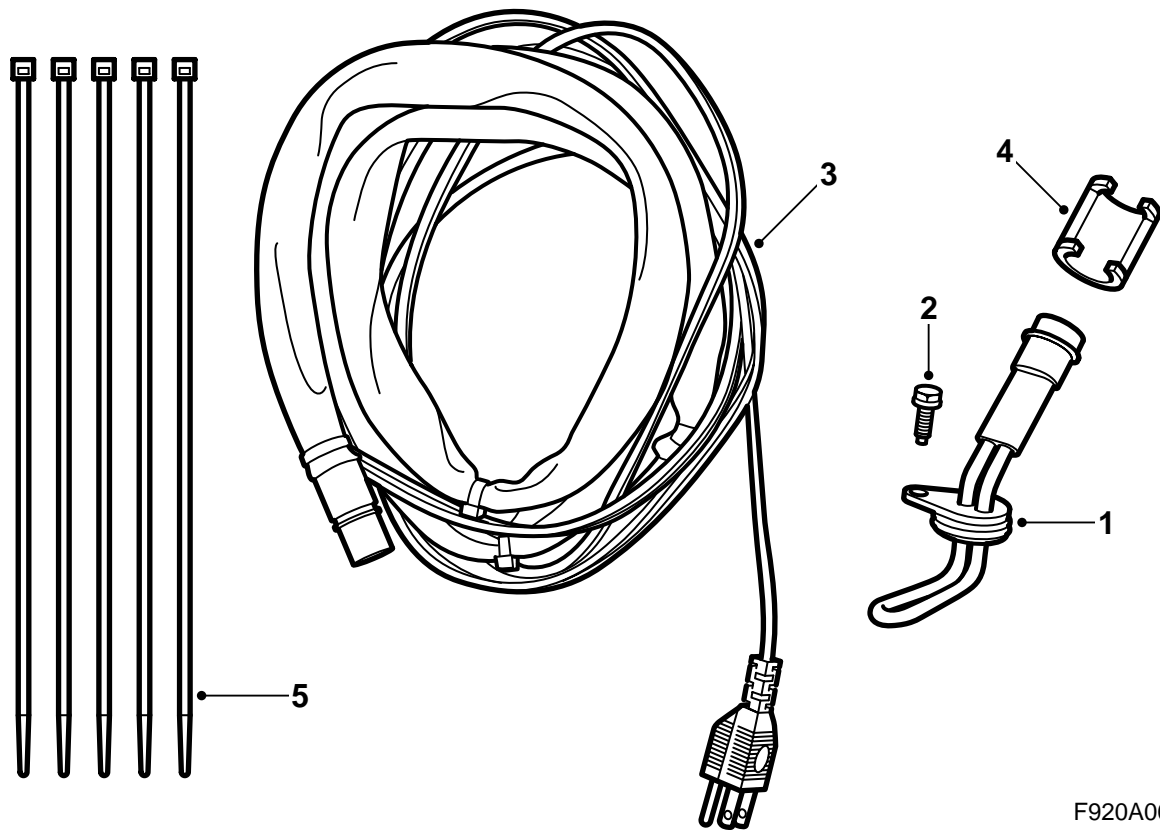

F920A008

- 1 Heating element
- 2 Screw M6x16
- 3 Extension cable
- 4 Lock clip
- 5 Cable tie (5)

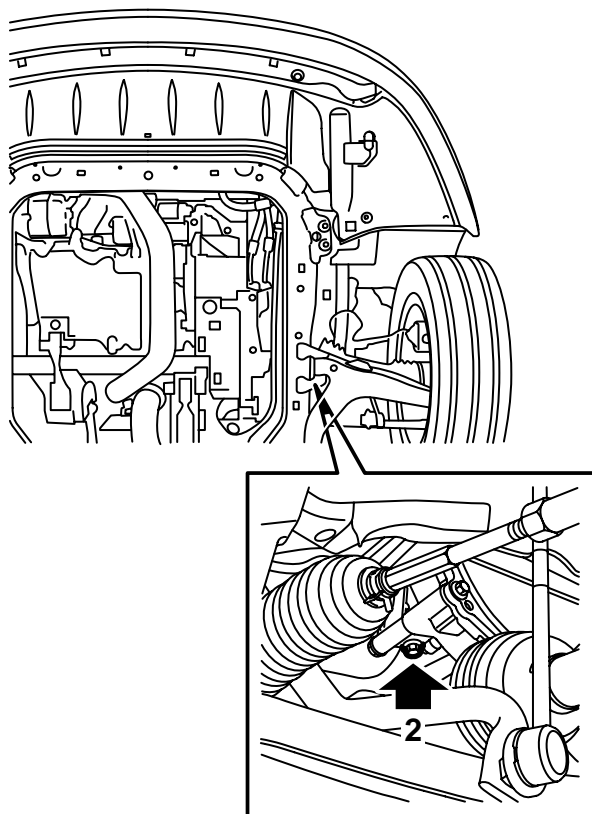

User instructions



WARNING

Not for interrupting current.

The connection cable must not be drawn out from the engine block heater. This connection must remain untouched.

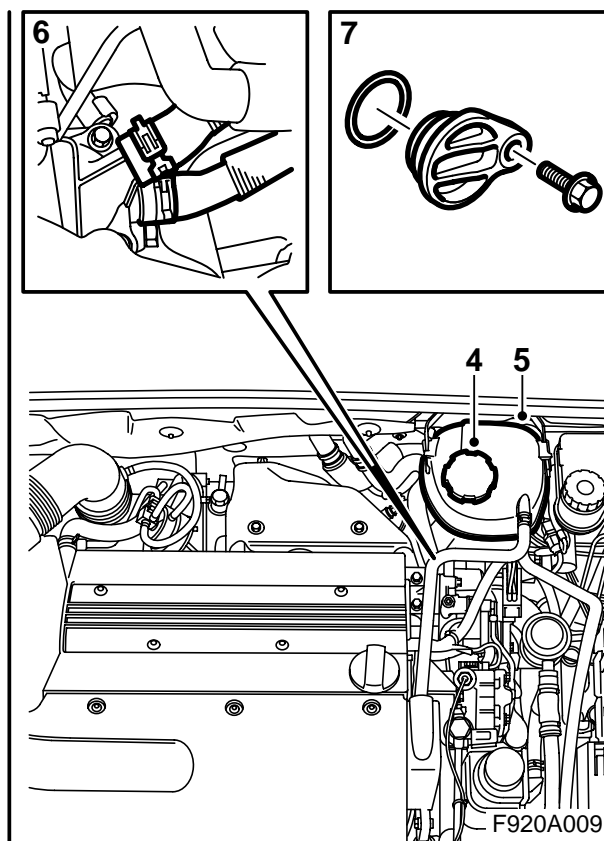

Fitting

- 1 Raise the car.
- 2 Place a receptacle under the engine, open the drain plug on the bottom of the coolant pump and drain the coolant.
- 3 Lower the car and remove the battery cover.
- 4 Remove the expansion tank cap.
- 5 Unhook the expansion tank and move it aside.
- 6 Detach the coolant hose which is connected between the thermostat housing and the expansion tank from the connection in the thermostat housing cover as well as the coolant hose that is connected right underneath that one.
- 7 Remove the cover below the connections of the two coolant hoses that were just removed.

Important

The O-ring may get stuck in the thermostat housing, but it must be removed.

The screw must be discarded as it may not be fitted together with the engine block heater.

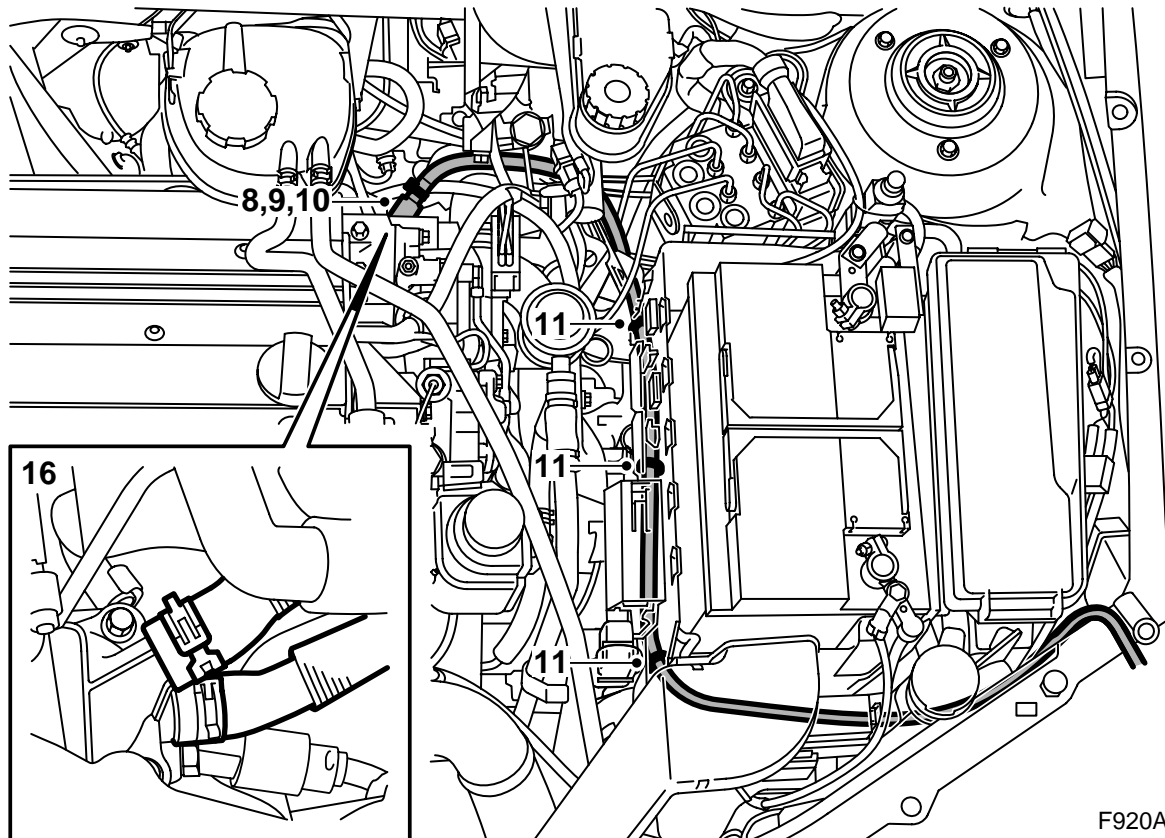

F920A010

- 8 Lubricate the O-ring of the engine block heater with acid-free petroleum jelly. Insert the heater into the cylinder block and fit it together with the screw from the kit.

Tightening torque 10 Nm (7.5 lbf ft)

- 9 Apply acid-free petroleum jelly, part no. 30 15 286, or the like to the intake cable O-ring and connect the cable to the engine block heater.

⚠ WARNING

It is important to lubricate the intake cable O-ring before connecting it and that all connections are pressed together securely. A loose contact could cause heat release and fire.

- 10 Fit the lock clip over the connection. A click should be heard when the lock clip is fitted correctly.
- 11 Move the intake cable forward, secure it under the battery tray (3 cable ties) and in one other spot, if necessary.
- 12 Roll up the cable and place it in a suitable spot in the engine bay.

⚠ WARNING

Check that the cable is not positioned in a way that it can be damaged by rotating parts or sharp edges. Damage to the cable can cause a short circuit or fire.

- 13 Raise the car.
- 14 Fit the drain plug on the bottom of the coolant pump.
- 15 Lower the car and fit the battery cover.
- 16 Connect the coolant hoses.
- 17 Fit the expansion tank.
- 18 Fill with coolant and fit the cap on the expansion tank. Check the integrity of the system.
- 19 Bleed the cooling system in the following way:

Note

The A/C or ACC should be turned OFF.

Fill the cooling system to the MAX level. Close the expansion tank cap. Start the engine and run at varying engine speeds until the radiator fan cuts in. Carefully open the expansion tank cap and top up to the MAX level. Close the cap. Switch off the engine and if necessary top the coolant up to the MAX level.